



MSME

सूक्ष्म, लघु एवं मध्यम उद्यम
MICRO, SMALL & MEDIUM ENTERPRISES

Government of India
Ministry of MSME

MSME-DEVELOPMENT AND FACILITATION OFFICE, THRISSUR

ANNUAL REPORT 2023-24



0487-2360536, 2360636



dcdi-thrissur@dcmsme.gov.in





**Government of India
Ministry of MSME
Office of Development Commissioner (MSME)**

ANNUAL REPORT 2023-24

**MSME – Development and Facilitation Office,
Thrissur**

Ayyanthole P.O., Kanjani Road, Kerala – 680003

Email: dcdi-thrissur@dcmsme.gov.in

Website: www.msmedithrissur.gov.in

Phone: 0487-2360536, 2360636

 MSME-Developmentand Facilitation Office, Thrissur,  [dcdi_thrissur](https://twitter.com/dcdi_thrissur)

FOREWORD

It is with pleasure and gratitude that I present the Annual Report of MSME – Development and Facilitation Office (MSME-DFO), Thrissur for the year 2023-24. This report not only provides a comprehensive overview about the achievements of MSME DFO Thrissur but also underscores our steadfast commitment to serving the MSME Sector and thus contributing to the growth of the Country.

The Ministry of MSME has played a pivotal role during the year for the sustainable development of MSME Sector by effectively implementing such programmes & policies meant for the sector. Ministry of MSME also introduced various initiatives to match to the dynamic socio-economic factors. One such major initiative is PM Vishwakarma Scheme. A significant section of the workforce of the Indian economy consists of artisans and craftspeople who work with their hands and tools, are usually self-employed and are generally considered to be a part of the informal or unorganised sector of the economy. These traditional artisans and craftspeople are referred to as 'Vishwakarmas' in the recently announced PM Vishwakarma Scheme which has been implemented as a Central Sector Scheme, fully funded by the Government of India, with an initial outlay of Rs 13,000 Crores. PM Vishwakarma Scheme envisages to provide end-to-end holistic support to the traditional artisans & craft people in scaling up their conventional products & services. It is expected that this initiative from the Ministry of MSME will bring a qualitative shift in the way these occupations are practiced by artisans and craftspeople and will uplift their socio-economic status as well as their quality of life.

Over the past year, MSME – Development and Facilitation Office, Thrissur, has demonstrated unwavering dedication to the mission of the Ministry of Micro, Small & Medium Enterprises, Government of India. As an effective link between Central and the State Government agencies, financial institutions, MSME Associations and other stakeholders engaged in the development of MSMEs, MSME – Development and Facilitation Office, Thrissur has taken up various activities. This annual report highlights the progress across key initiatives, including the progress of implementation of various schemes under the Ministry, National, State and District Level Awareness Programmes, National level workshops, Vendor Development programmes, programmes for improving the efficiency of MSMEs by adopting best practices, Entrepreneurial Awareness Programmes, Skill Development Programmes, Management Development Programmes, etc. Further, MSME-DFO, Thrissur provided need based support to the Entrepreneurs from MSME sector by providing various essential general inputs through its techno – managerial consultancy regarding selection of product, finding out the market, availability of raw materials and selection of machinery, information on technical know-how sources, information on availability of credit, production process, managerial inputs, etc. as required by the aspiring & existing entrepreneurs. During the year, this Office provided assistance to a total of 81,813 prospective and existing entrepreneurs in the State through various activities. These accomplishments are a testament to our collective efforts in driving positive change and delivering impactful outcomes for the stakeholders.

I extend my sincere appreciation to all Officers and Staff of MSME-DFO, Thrissur, whose professionalism and commitment continue to inspire us. I also thank Ministry of MSME, O/o Additional Secretary & Development Commissioner (MSME), O/o Industries Minister, Government of Kerala, O/o Principal Secretary (Industries), Government of Kerala, O/o State Director of Industries & Commerce, GM DICs, prominent MSME associations, Financial Institutions, Academic Institutions and other Central and State Government departments & agencies connected with the MSME Sector, as well as the MSME entrepreneurs & citizens we serve, for their invaluable, guidance, collaboration and support.

As we look forward, our focus remains on fostering transparency, accountability, and efficiency in all our endeavors. We are committed to enhance service delivery and meet the emerging needs of our diverse stakeholders. Together, we are charting a course toward a brighter future, guided by a vision of a prosperous and inclusive society to the fullest extent possible in productively utilizing the resources under our control & as per the mandate given to us.

Thrissur
18.06.2024



 (G.S. PRAKASH)
 Joint Director and Head of Office

Table of Contents

Sl.No.	Content	Page No
	Foreword	2
1	Chapter 1 – Introduction	4 - 6
2	Chapter 2 – Policy and Status of MSMEs in the State	7-14
3	Chapter 3 – Credit Flow to MSMEs in the State	15-20
4	Chapter 4 – Artisans to Entrepreneurs - PM Viswakarama	21-48
5	Chapter 5 - Champions MSMEs and Innovation	49-67
6	Chapter 6 – Market and Export Promotion	68-101
7	Chapter 7 - Infrastructure Development and Cluster Development	102-112
8	Chapter 8 – Entrepreneurship and Skill Development	113-126
9	Chapter 9 – Grievance Redressal, Publicity and Out Reach Programmes	127-151
10	Chapter 10 – Establishment, Capital Expenditure and Budget	152-162
11	Chapter 11 – Official Language Implementation	163 -166
12	Chapter 12 – Outcomes of Initiatives of MSME-DFO, Thrissur	167-185

Chapter 1

Introduction

1.1. Importance of MSME Sector

The Micro, Small and Medium Enterprises (MSME) sector has emerged as a highly vibrant and dynamic sector of the Indian economy over the last five decades. It contributes significantly in the economic and social development of the country by fostering entrepreneurship and generating large employment opportunities at comparatively lower capital cost, next only to agriculture. MSMEs are complementary to large industries as ancillary units and this sector contributes significantly in the inclusive industrial development of the country. The MSMEs are widening their domain across sectors of the economy, producing diverse range of products and services to meet demands of domestic as well as global markets.

Ministry of Micro, Small & Medium Enterprises, Government of India envisions a progressive MSME sector by promoting growth and development of the Sector, including Khadi, Village and Coir Industries, in cooperation with concerned Ministries/Departments, State Governments and other Stakeholders, through providing support to existing enterprises, adopting cutting edge technologies and encouraging creation of new enterprises. The Ministry runs various schemes aimed at financial assistance, technology assistance and up gradation, infrastructure development, skill development and training, enhancing competitiveness and market assistance of MSMEs. These initiatives have been taken to ensure that demographically as well as geographically weaker sections will get benefit.

1.2. Definition of MSMEs

The present classification of MSMEs has come into effect from 1st July, 2020 (as per the Gazette Notification issued on 1st June 2020 which has further been superseded by S.O. 2119(E) dated 26.06.2020 w.e.f. 01.07.2020). The earlier criterion of classification of MSMEs under MSME Act, 2006 was based on investment in plant and machinery / equipment. It was different for manufacturing and services units. It was also very low in terms of financial limits. Since then, the economy has undergone significant changes. A revision in MSME criteria of classification was announced in the Aatma Nirbhar Bharat package on 13th May, 2020. As a result, a composite criterion of classification for manufacturing and service units has been notified on 26.06.2020, with guidelines regarding composite criteria to facilitate the present and prospective entrepreneurs. Now, there will be no difference between manufacturing and service sectors. Also, a criterion of turnover has been added in the previous criteria of classification based only on investment in plant and machinery. This criterion is expected to bring about many benefits that will aid MSMEs to grow in size. It has also been decided that the turnover with respect to exports will not be counted in the limits of turnover for any category of MSME units whether micro, small or medium.

1.3. Organizational Structure

The Ministry of MSME, Government of India consists of Small & Medium Enterprises (SME) Division, Agro & Rural Industry (ARI) Division, Administration & Financial Institutions (AFI), Integrated Finance (IF) Wing and Data Analytics and Technical Co-ordination (DATC) Wing, besides the Office of the Development Commissioner (DCMSME) as an attached office and other subordinate organisations.

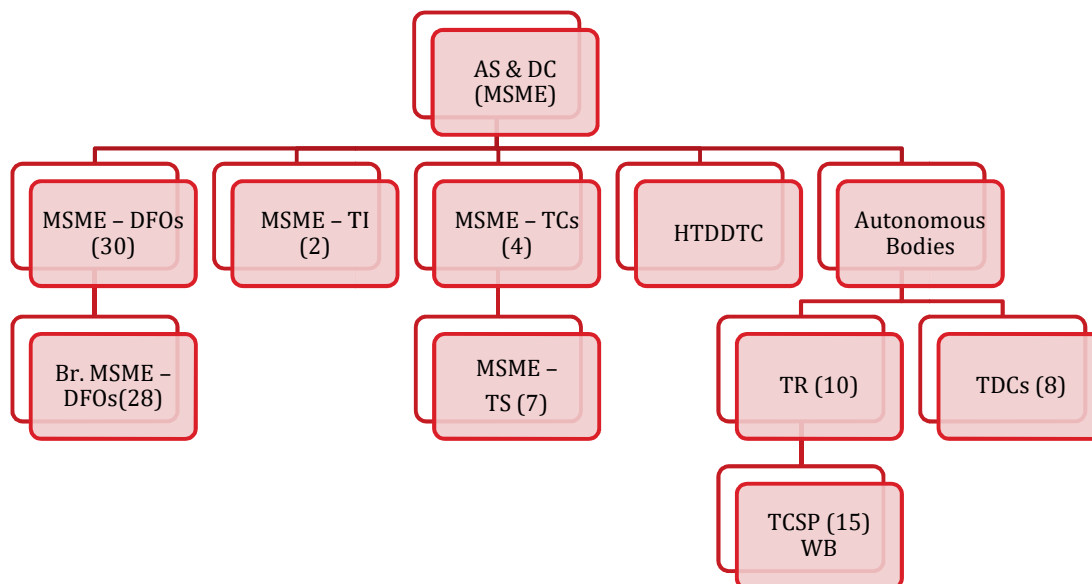

1.3.1. About the MSME - Development and Facilitation Office, Thrissur

MSME - Development and Facilitation Office, Thrissur, Kerala, a field outfit of Development Commissioner (MSME) under the Ministry of MSME, Government of India, started in 1956. The Institute is engaged in the tasks of promotion and development of MSMEs in the State. Apart from offering various Techno-Economic and Managerial consultancy and support services, the Institute also conducts Entrepreneurial, Technical and Managerial training programmes for the benefit of prospective and existing entrepreneurs. A Nucleus Cell, under the administrative control of MSME-DFO, Thrissur is also functioning at Amini Island of Lakshadweep to look after the various needs of MSME sector in the Lakshadweep Islands.

The DFO is dedicated to provide need based support to Micro, Small and Medium scale entrepreneurs by providing various essential inputs through its technical consultancy regarding selection of product, finding out the market, availability of raw materials, use of machinery, economically viable layout and production process, managerial consultancy, etc. The Office also helps MSMEs by imparting knowledge on new practices like modernization, technology up-gradation, acquiring international quality systems, energy conservation, pollution control etc. MSME-DFO gave due importance to the schemes of the Ministry of MSME, Govt of India and create massive awareness about the schemes in the State and UT.

The DFO operates a number of reimbursement schemes and facilitates participation in Industrial Exhibitions (domestic and international) in order to provide a platform to MSMEs to improve their productivity, quality and to expand their market and establish linkage with the

large scale units and public sector undertakings for business transactions. There are programmes to create awareness on Public Procurement Policy and to help MSMEs to ensure flow of supply to large PSUs/Government Departments. Apart from that the Office offers several skill development programmes.

Important areas of concentration of the Institute in order to support the enhancement of MSME sector is given as bullet points below:

- Implementation of Programmes and Policies of Ministry of MSME at State level and Coordination with Stakeholders
- Cluster Development Programmes
- Intellectual Property Facilitation Cell
- MSME Champions Scheme
- Marketing Assistance
- Promotion of Export
- Central Workshop facilities
- Business/Technical/Managerial/Entrepreneurial Consultancy and Services

Apart from the above mentioned activities, the Institute provides various services for nourishing the MSMEs in the State. The MSME-DFO closely co-ordinates with other State and Central Government organizations, NGOs, Financial Institutions etc. to frame strategies for development of MSME sector.

Chapter 2

An Overview of MSME Sector and Recent Initiatives

2.1. MSME Sector in India

The Micro, Small & Medium Enterprises (MSMEs) is considered as the backbone of Indian economy that has contributed substantially in the socio-economic development of the nation. It generates employment opportunities and works in the development of backward and rural areas. The MSMEs are widening their domain across sectors of the economy, producing diverse range of products and services to meet demands of domestic as well as global markets. As per the data available with Central Statistics Office (CSO), M/o Statistics & Programme Implementation, the contribution of MSME sector in Country's Gross Value Added (GVA) and Gross Domestic Product (GDP) is around 33% i.e. one-third during the period from 2014-15 to 2018-19.

The MSME sector in India is diverse in terms of size, levels of technology employed, and products. As per the 73rd round of NSS data for 2015-16, there were 633.88 lakh unincorporated non-agricultural MSMEs in the country engaged in different economic activities. 31 per cent MSMEs were found to be engaged in manufacturing activities, while 32 per cent were in trade and 33 per cent in other services (196.65 lakh in manufacturing, 230.35 lakh in trade, 206.85 lakh in other services and 0.03 lakh in non-captive electricity generation and transmission) excluding those MSMEs registered under Factories Act, 1948. MSME sector provided employment for 11.10 crore workers (3.60 crore in manufacturing, 3.87 crore in trade and 3.62 crore in other services and 0.007 crore in non-captive electricity generation and transmission) in the rural and urban areas across the country. Again, out of an estimated 633.88 lakh MSMEs, 324.09 lakh MSMEs (51 per cent) were in rural areas and 306.43 lakh MSMEs (49 per cent) were in the urban areas.

2.2. MSME Sector in Kerala

The Micro, Small and Medium Enterprises (MSME) sector is emerging as a major income generating and employment providing sector in Kerala. Kerala, with its excellent connectivity, communication network, availability of highly skilled human resources, and relatively good industrial infrastructure, is highly suited for the growth of the MSME sector. The MSME sector helps in industrialization of rural and backward areas, and provides employment to youth and socially disadvantaged groups such as SC, ST, women and persons with disabilities. The economic growth of Kerala is related to the development of MSMEs. Department of Industries and Commerce, Government of Kerala is implementing various schemes for facilitating the MSMEs.

Within the MSME sector, there is a significant increase of micro enterprises, both in terms of working enterprises and employment. The industries coming under this sector are handicrafts, handloom, khadi, food processing industries, garment making and textile industries and industries related to coir, wood, bamboo, plastic, rubber, leather, and clay

products. MSMEs produce over 8000 various MSME products ranging from traditional to high-tech items are manufactured by MSMEs.

The Government of Kerala decided to celebrate 2022-23 as the 'Year of Enterprises' to encourage and promote MSMEs in the State. The Directorate of Industries and Commerce was entrusted with the initiative of "Setting up of One Lakh Enterprises in 2022-23". The targets are to establish one lakh enterprises through joint efforts of various departments and to create three lakh employments in the year 2022-23. The broad strategy adopted encompasses the creation of enterprise facilitation systems at the grassroots level, the convergence of activities of various industrial stakeholders, introduction of new incentive schemes and policies, and thereby create a conducive ecosystem to foster the establishment of new enterprises as well as the scaling up of existing enterprises in the State. The Economic Review of 2023 of Government of Kerala, states that, The Government was able to achieve the ambitious target of commencing one lakh new enterprises within a remarkable period of 250 days from April 1 to December 7, 2022. In 2022-23, the State witnessed a remarkable achievement with the launch of 1,39,840 new enterprises, backed by a staggering investment of Rs 8,421.63 crore. This unprecedented growth has led to the creation of 3,00,051 new employment opportunities in the State. Around one-third of these newly formed enterprises are promoted by women entrepreneurs. The top sectors in which new units have been established include Agro & Food Processing, Textiles and Garments and Service Activities.

Fig 2.1: Number of new Micro, Small and Medium units and employment created in MSMEs in 2021-22 and 2022-23

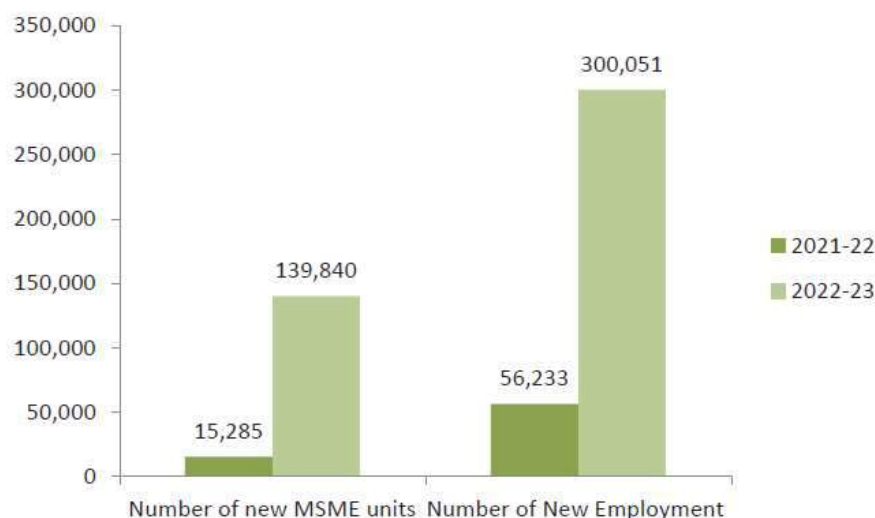

Source: Economic Review 2023

Vide Notification dated 26.06.2020 of Ministry of MSME, Government of India, the MSMEs were classified on the composite criteria of investment and turnover for classification vide which an enterprise shall be classified as a micro, small or medium enterprise on the basis of the following, namely:-

- i. *a micro enterprise*, where the investment in plant and machinery or equipment does not exceed one crore rupees and turnover does not exceed five crore rupees;

- ii. *a small enterprise*, where the investment in plant and machinery or equipment does not exceed ten crore rupees and turnover does not exceed fifty crore rupees; and
- iii. *a medium enterprise*, where the investment in plant and machinery or equipment does not exceed fifty crore rupees and turnover does not exceed two hundred and fifty crore rupees.

If an enterprise crosses the ceiling limits specified for its present category in either of the two criteria of investment or turnover, it will cease to exist in that category and be placed in the next higher category but no enterprise shall be placed in the lower category unless it goes below the ceiling limits specified for its present category in both the criteria of investment as well as turnover.

The details of MSMEs registered under Udyam Registration are as follows (Kerala and Lakshadweep):

**Table 2.1: Number of MSMEs Registered under UR
(During period from 01.04.2023 to 31.03.2024)**

District Name	UR (Manufacturing)	UR (Services)	Total
Alappuzha	2895	9400	12295
Ernakulam	6007	20834	26841
Idukki	1494	5560	7054
Kannur	2857	12555	15412
Kasaragod	1966	5507	7473
Kollam	3603	10067	13670
Kottayam	2625	8262	10887
Kozhikode	6064	17292	23356
Malappuram	4997	14847	19844
Palakkad	4835	13636	18471
Pathanamthipta	1419	5415	6834
Thiruvananthapuram	6195	18953	25148
Thrissur	5398	14166	19564
Wayanad	1503	3954	5457
Total	51858	160448	212306
UT of Lakshadweep	31	240	271

It is evident that the majority of the MSMEs in Kerala are belonging to Micro Category. The following table shows the category wise details of MSMEs in Kerala.

Table 2.2: Category-wise Details of Udyam Registrations in Kerala and UT of Lakshadweep (As on 31.03.2024)

Sl No.	District Name	Total Count	Micro	Small	Medium
1	Alappuzha	34254	33423	794	37
2	Ernakulam	83273	78814	4081	378
3	Idukki	18380	17882	477	21
4	Kannur	41404	40428	916	60
5	Kasaragod	19857	19438	398	21
6	Kollam	38950	37745	1152	53
7	Kottayam	31704	30576	1044	84
8	Kozhikode	57045	55625	1287	133
9	Malappuram	47516	46196	1248	72
10	Palakkad	48133	47023	1021	89
11	Pathanamthipta	19290	18871	397	22
12	Thiruvananthapuram	71516	70052	1369	95
13	Thrissur	56606	54926	1543	137
14	Wayanad	14550	14237	294	19
Total:		582478	565236	16,021	1,221
UT of Lakshadweep		851	851	0	0

The following table shows the top 15 sectors in the manufacturing activities among the MSMEs in Kerala:

Table 2.3: Top 15 Sectors in Manufacturing as per UR

Sl No	NIC Code	2 Digit NIC Code Description	Total Count	Micro	Small	Medium
1	10	Manufacture of food products	72199	70031	1877	291
2	14	Manufacture of wearing apparel	21849	21731	107	11
3	13	Manufacture of textiles	20134	19873	229	32
4	32	Other manufacturing	19881	18745	973	163
5	41	Construction of building	15058	14533	498	27

6	43	Specialized construction activities	13242	12800	433	9
7	31	Manufacture of furniture	9146	8945	182	19
8	16	Manufacture of wood and products of wood and cork, except furniture; manufacture of articles of straw and plaiting materials	8565	8070	478	17
9	20	Manufacture of chemicals and chemical products	8490	8194	277	19
10	42	Civil Engineering	7699	6997	658	44
11	25	Manufacture of fabricated metal products, except machinery and equipment	7343	7037	257	49
12	22	Manufacture of rubber and plastics products	5746	5080	578	88
13	1	Crop and animal production, hunting and related service activities	5386	5249	115	22
14	33	Repair and installation of machinery and equipment	4978	4799	170	9
15	23	Manufacture of other non-metallic mineral products	4976	4758	208	10

The following table shows the top 15 sectors in the service activities among the MSMEs in Kerala:

Table 2.4: Top 15 Sectors in Services

Sl No	NIC Code	2 Digit NIC Code Description	Total Count	Micro	Small	Medium
1	49	Land transport and transport via pipelines	61226	60731	468	27
2	96	Other personal service activities	44755	44511	236	8
3	56	Food and beverage service activities	34700	33894	777	29
4	79	Travel agency, tour operator and other reservation service activities	18814	18703	104	7
5	74	Other professional, scientific and technical activities	15973	15565	384	24
6	62	Computer programming, consultancy and related activities	14708	14461	227	20
7	77	Rental and leasing activities	13306	13130	162	14
8	63	Information service activities	12732	12659	65	8

9	85	Education	10921	10713	173	35
10	86	Human health activities	10533	9924	525	84
11	82	Office administrative, office support and other business support activities	9477	9089	360	28
12	81	Services to buildings and landscape activities	9066	8782	273	11
13	52	Warehousing and support activities for transportation	9485	8766	655	64
14	95	Repair of computers and personal and household goods	7437	7234	183	20
15	71	Architecture and engineering activities; technical testing and analysis	6008	5814	178	16

Table 2.5: Cumulative Details of Udyam Registrations in Kerala and UT of Lakshadweep (As on 31.03.2024)

District Name	UR (Manufacturing)	UR (Services)	Total
Alappuzha	9506	24748	34254
Ernakulam	23749	59524	83273
Idukki	4560	13820	18380
Kannur	9134	32270	41404
Kasaragod	5739	14118	19857
Kollam	10952	27998	38950
Kottayam	8517	23187	31704
Kozhikode	15558	41487	57045
Malappuram	13475	34041	47516
Palakkad	13886	34247	48133
Pathanamthipta	4565	14725	19290
Thiruvananthapuram	18505	53011	71516
Thrissur	17959	38647	56606
Wayanad	3937	10613	14550
Total	160042	422436	582478
UT of Lakshadweep	124	727	851

2.3. Udyam Registration Drives

During the financial year MSME-DFO, Thrissur has arranged facilities at various venues to support the MSMEs to get Udyam Registration and thus to help them to avail various benefits from various Government Organisations.

Table 2.6: Details of UR Drives

Sl No	Date of programme	Nature of programme	Venue of Programmes
1	11.10.2023	National Workshop on Export Marketing	Hotel Abad Plaza, Kochi
2	30.10.2023	ESDP on food processing, ESDP on fabric painting	MSME-DFO, Thrissur
3	29.09.2023	Vendor Development Programme	MSME-DFO, Thrissur
4	30.09.2023	Vendor Development Programme	MSME-DFO, Thrissur
5	04.11.2023	Entrepreneurship Awareness Programme	Kottopadam H.S.S, Palakkad
6	07.11.2023	Entrepreneurship Skill Development Programme	MSME-DFO, Thrissur
7	10.11.2023	Entrepreneurship Awareness Programme	Block Panchayath Hall, Vaikom
8	10.11.2023	Entrepreneurship Awareness Programme	Amrita Viswavidyapeetham, Kollam
9	17.11.2023	Entrepreneurship Awareness Programme	Le prime Inn , Adimali
10	17.11.2023	Entrepreneurship Awareness Programme	SAME Research centre, Guruvayoor
11	21.11.2023	Entrepreneurship Awareness Programme	Pattancheri Cooperative Bank Hall , Palakkad
12	22.11.2023	Entrepreneurship Awareness Programme	MSME-DFO, Thrissur
13	22.11.2023	Entrepreneurship Awareness Programme	Woodlands Lodge, Cherthala
14	23.11.2023	Entrepreneurship Skill Development Programme	S S M Poly technique, Thiroor
15	24.11.2023	Entrepreneurship Awareness Programme	Navajyothi B.Ed College, Olari
16	28.11.2023	Entrepreneurship Skill Development Programme	Ansar College, Perumbilavu
17	30.11.2023	Entrepreneurship Awareness Programme	Sargam Auditorium, Kannur

A few photographs from the Udyam Registrations are as follows:





2.4. Significant Policy Developments during 2023-24

In pursuance of Para 9(4) of this Ministry's Notification Number S.O.2119(E) dated 26.06.2020, to facilitate the speedy disposal of grievances related to discrepancies or complaints pertaining to updating requests, and to take action on the recommendations of the Directorate of Industries for cancellation/amendments of the Udyam Registration Certificate within 48 hours, the Competent Authority authorizes MSME DFOs to take such action to resolve the issues in the States/UTs of their jurisdiction on behalf of the ministry.

Chapter 3

Credit Flow to MSMEs in the State

3.1 Credit Related Activities of MSME-DFO, Thrissur

During the Financial Year, Officers from MSME-DFO, Thrissur provided assistance to individual entrepreneurs on credit related matters and undertaken various other activities. Officers participated in various forums like State Level Review Meeting (SLRM) organised by State Level bankers Committee (SLBC) under the chairmanship of Chief Secretary, Government of Kerala and District Level Credit Review Meetings (DLRC) under the chairmanship of respective District Collector to review the credit flow to different sectors as organised by Lead District Banks. Officers requested the SLBC & DLRC forums to review the progress of various credit facilities extended to MSMEs regularly so that these forums could effectively monitor the credit flow to MSME sector. Apart from these, Officers also attended the Empowered Committee Meetings on MSME held under the chairmanship of Regional Director, RBI in online/offline modes to review the performance of banks with respect to the MSME Sector. Further, Officers also attended Town Hall Meetings organized by RBI and handled sessions on various Credit Schemes of Ministry of MSME apart from other Schemes. This office also coordinated in the conduct of Webinars which directly/indirectly cater to the financial health of MSMEs.

3.2 Credit Guarantee Trust for Micro and Small Enterprises (CGTMSE)

Credit Guarantee Trust for Micro and Small Enterprises is an important Scheme of Ministry of MSME to facilitate enterprises that fall under Manufacturing, Service as well as Retail Sector by ensuring availability of bank credit without the hassles of collaterals / third party guarantees. This would be a major source of support to the first generation entrepreneurs to realize their dream of setting up a unit of their own Micro and Small Enterprise (MSE). To operationalize the scheme, Government of India and SIDBI set up the Credit Guarantee Fund Trust for Micro and Small Enterprises (CGTMSE). The following are the salient features of CGTMSE:

Table 3.1: Features of CGTMSE

Category (including Trading activity)	Maximum extent of Guarantee Coverage where guaranteed credit facility is		
	Upto ₹ 5 lakh	Above ₹ 5 lakh & upto ₹ 50 lakh	Above ₹ 50 lakh & upto ₹ 500 lakh
Micro Enterprises	85%	75%	75%
MSEs located in North East Region (incl. Sikkim, UT of Jammu & Kashmir and UT of Ladakh)		80%	
Women entrepreneurs / SC/ST entrepreneurs / MSEs situated in Aspirational District / ZED certified MSEs / Person with Disability (PwD) / MSE promoted by Agniveers		85%	
All other category of borrowers		75%	

The revised Annual Guarantee Fee (AGF) structure under Credit Guarantee Scheme (CGS -I) applicable to all the guarantees approved/ renewed on or after April 01, 2023 are given in the table below:

Table: 3.2: Annual Guarantee Fee (AGF) structure

Slab	Standard Rate (pa)*
0-10 lakh	0.37
Above 10-50 lakh	0.55
Above 50 lakh-1 crore	0.60
Above 1-2 crore	1.20
Above 2-5 crore	1.35
<i>*Above 2-5 crore 1.35 AGF will be charged on the guaranteed amount for the first year and on the outstanding amount for the remaining tenure of the credit facility.</i>	

The following shows the details of CGTMSE Coverage in the FY 2023-24 as per SLBC, Kerala.

CGTMSE					
CGTMSE Coverage Details*					
Amt in Lakhs					
CGTMSE covered accounts during last quarter		CGTMSE claim applied accounts during last quarter		CGTMSE claim settled accounts during last quarter	
Nos	Amount	Nos	Amount	Nos	Amount
9119	1094.29	1106	42.85	1060	46.51

*Compiled from banks who have submitted the data

Source: SLBC Kerala

3.3 Prime Minister's Employment Generation Programme (PMEGP)

Ministry of MSME, Government of India is implementing Prime Minister's Employment Generation Programme (PMEGP), to facilitate generation of employment opportunities for unemployed youth across the country by assisting setting up of micro-enterprises in non-farm sector. KVIC is national level nodal agency. At State/District level State office of KVIC, State KVIBs and DICs are the implementing agencies. Coir Board is the implementing Agency for the Coir Units.

Entire process of application to sanction and release of funds by banks is online through the portal <https://www.kviconline.gov.in/pmegportal/pmegphome/index.jsp>

Following major modifications/improvements have been made in the existing Scheme:

- i. Increasing the maximum project cost from existing Rs.25 lakh to Rs. 50 lakh for manufacturing units and from existing Rs.10 lakh to Rs.20 lakh for service units.
- ii. Modified definition of village industry and Rural Area for PMEGP. Areas falling under Panchayati Raj institutions to be accounted under rural area, where as areas under Municipality to be treated as urban area.
- iii. All Implementing Agencies are allowed to receive and process applications in all areas irrespective of the rural or urban category.
- iv. PMEGP applicants under aspirational districts and transgender will be treated as Special category applicants and entitled for higher subsidy.
- v. Higher rate of Margin Money subsidy - 25% of the project cost in urban area and 35% of the project cost in rural areas, for special category applicants including, SC, ST, OBC, women, Transgender, Physically Disabled, NER, Aspirational and Border district applicants. For General category applicants subsidy is 15% of the project cost in urban area and 25% of the project cost in rural areas.

The performance of PMEGP Scheme in Kerala for the year 2023-23 is as follows:

Table 3.3: Performance of PMEGP Scheme in Kerala (2022-23)

Prime Minister Employment Generation Programme (PMEGP)				
Margin Money Disbursed to State in FY - 2023-24				
S.No.	State Name	Number of Projects	Margin Money [Rs. In Crore]	Employment
1	KERALA	613	14.16	4904

The following figures and tables from SLBC, Kerala shows some important parameters related to credit facilities to MSMEs in Kerala:

MSME Advances Outstanding (Y-o-Y) (AMT. IN CR.)

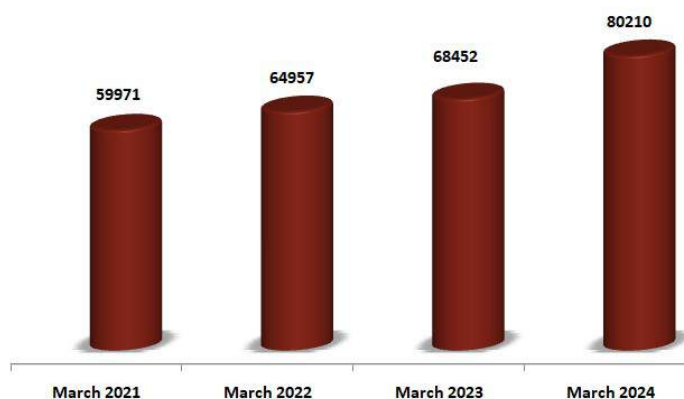

Source: SLBC Kerala

SHARE OF MSME OUTSTANDING - MARCH 2024

Banking Group	No.	Amt. in Cr.
Total- Public Sector Commercial Banks	844725	37783
RR B - KERALA GRAMIN BANK	86438	1858
Total- Pvt Sector Commercial Banks	145940	39657
Total- Small Finance Banks	211341	911
Total - Comm. Banks + RRB + SFB	1288444	80210

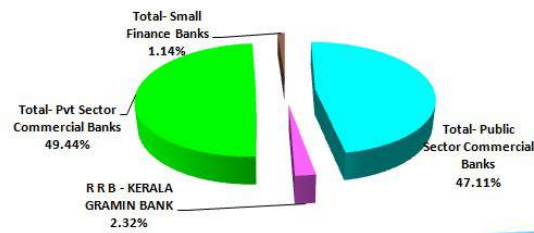

Source: SLBC Kerala

Outstanding in sub sectors- MARCH 2024 (AMT. IN CR.)

BANK	Manufacturing		Services		Retail Trade		Other MSMEs		TOTAL MSME	
	No.	Amt.	No.	Amt.	No.	Amt.	No.	Amt.	No.	Amt.
Total- Public Sector Commercial Banks	278754	11696	31817 7	1943 4	245716	6244	2078	408.42	844725	37783
RR B - KERALA GRAMIN BANK	18112	602	37534	772	30792	485	0	0.00	86438	1858
Total- Pvt Sector Commercial Banks	42242	11560	96038	2531 0	7659	2728	1	59.26	145940	39657
Total- Small Finance Banks	82146	370	90134	262	39061	279	0	0.00	211341	911
Total - Comm. Banks + RRB + SFB	421254	24228	54188 3	4577 8	323228	9737	2079	468	1288444	80210

Source: SLBC Kerala

Sub sector share in total MSME

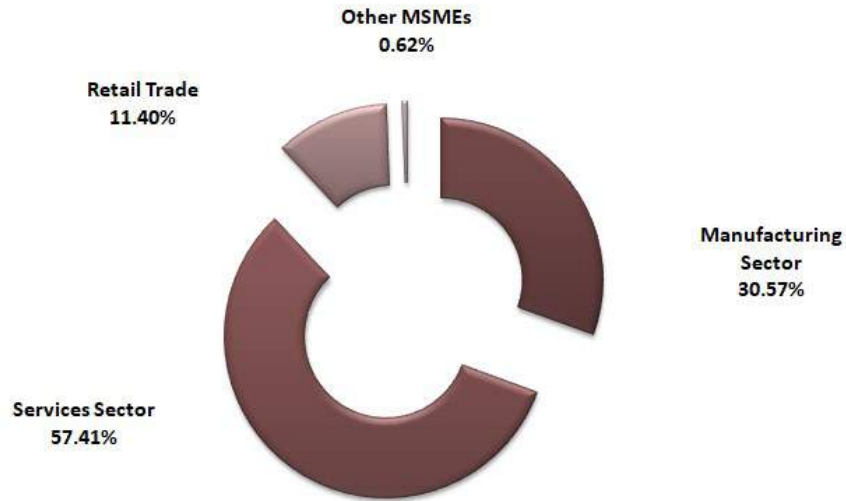

Source: SLBC Kerala

% of NPA in MSME Advances

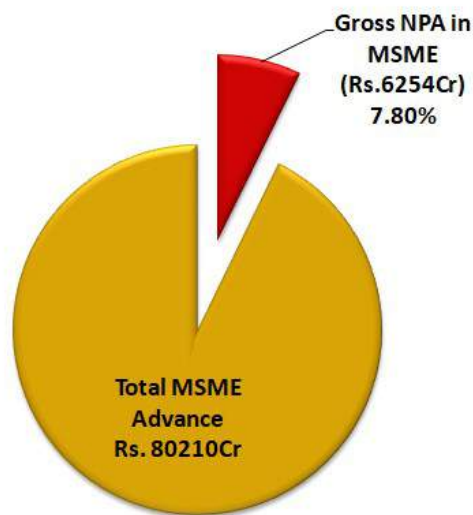

Source: SLBC Kerala

PMEGP Loans to Micro and Small Enterprises

Amt in Crores

PMEGP Loan without Collateral							
Micro Enterprises				Small Enterprises			
Outstanding as on 31.03.2024		Loan sanctioned during the Quarter (From January 2024 to March 2024)		Outstanding as on 31.03.2024		Loan sanctioned during the Quarter (From January 2024 to March 2024)	
No	Amt	No	Amt	No	Amt	No	Amt
20119	811.79	1393	65.99	220	7.77	36	1.72

Source: SLBC Kerala

Chapter 4

Artisans to Entrepreneurs - PM Vishwakarma

4.1. A brief about the Scheme

PM Vishwakarma, a Central Sector Scheme, fully funded by the Government of India, with an initial outlay of Rs 13,000 crore was launched by Hon'ble Prime Minister on 17th September, 2023 which envisage to provide holistic end-to-end support to the artisan/crafts person pertaining to selected 18 trades and is expected to bring a qualitative shift in the way these trades are practiced by artisans and to uplift their socio-economic status as well as quality of life. The scheme is conjointly implemented by the Ministry of Micro, Small & Medium Enterprises (M/o MSME), Ministry of Skill Development and Entrepreneurship (MSDE) and the Department of financial Services (DFS), Ministry of Finance, Government of India. Ministry of MSME, Govt of India is the Nodal Ministry for the Scheme. The 18 Trades selected under the Scheme are as follows:

Table 4.1: 18 Trades selected under the Scheme

S No	Initial 18 Trades	S No	Initial 18 Trades
Wood Based		Leather Based	
1	Carpenter (Suthar/ Badhai)	10	Cobbler(Charmkar)/Shoesmith/ Footwear artisan
2	Boat Maker	Construction	
Iron/ Metal Based		11	Mason (Raajmistri)
3	Armourer	Others	
4	Blacksmith (Lohar)	12	Basket/Mat/Broom Maker/ Coir Weaver
5	Hammer & Tool Kit Maker	13	Doll & Toy Maker (Traditional)
6	Locksmith	14	Barber (Naai)
Gold/ Silver Based		15	Garland Maker (Malakaar)
7	Goldsmith (Sonar)	16	Washerman (Dhobi)
Clay Based		17	Tailor (Darzi)
8	Potter (Kumhaar)	18	Fishing Net Maker
Stone Based			
9	Sculptor (Moortikar, Stone Carver), Stone Breaker		

Table 4.2: Benefits under PM Vishwakarma

S.N	Type	Description
1.	Registration	Recognition as Vishwakarma: PM Vishwakarma Certificate & ID Card
2.	Skill Upgradation	(a) Skill Verification followed by 5-7 days Basic Training (b) 15 days or more Advanced Training (c) Training Stipend: Rs 500 per day
3.	Toolkit Incentive	Rs 15,000 through e-vouchers/e-RUPI

4.	Credit Support	<p>(a) Collateral free Enterprise Development Loans: Up to Rs 1 lakh (First Tranche for 18 months repayment) Up to Rs 2 lakh (Second Tranche for 30 months repayment)</p> <p>(b) Concessional Rate of Interest @ 5% subject to interest subvention cap up to 8% by GoI (Credit Oversight Committee may revise subvention cap keeping in view prevailing interest rates)</p> <p>(c) Credit Guarantee fees to be borne by GoI</p>
5.	Incentive for Digital Transaction	Re. 1 per transaction for maximum 100 transactions per month
6.	Marketing Support	Corpus for quality certification, branding, advertising, publicity and other marketing activities

4.2. Efforts taken by DFO, Thrissur to implement the Scheme in the State

MSME DFO, Thrissur has been actively involved in the PM Vishwakarma Scheme starting from its conceptualization to execution at field level. At the initial stages, data of all Panchayats and Urban Local Bodies was compiled and handed over to O/o DC(MSME). Later on State Government was requested to nominate a Nodal Agency for the Scheme and subsequently, KADCO was nominated as the Nodal Agency for PM Vishwakarma for Kerala. Due to the efforts from MSME DFO, Thrissur, the Government of Kerala constituted the State Level/District Level Committees on 18th September, 2023 and later on Orders were issued from the Office of Principal Director (LSGD) and Director (Industries) explaining the mode in which the various verifications have to be conducted under the Scheme. Further, MSME-DFO, Thrissur has organized various Webinars at the request of DICs/LSGDs and also has handled physical sessions at the request of Artisan Associations. All officers of MSME-DFO are part of the District Level Implementation committee and JD/HoO is the chairperson of the Tier III Screening Committee that gives final approval to the applications received. The inauguration of PM Vishwakarma was live broadcasted at Kavaratti, Ernakulam and Thiruvananthapuram and the reports on the same are as below:

- On 17.09.2023, MSME DFO, Thrissur coordinated with Ministry (Railways) in conducting the PM Vishwakarma programme inaugural function at Tagore Theatre, Thiruvananthapuram. Hon'ble Union Minister for External Affairs Dr. S. Jaishankar was the Chief Guest for the programme. MSME-DFO, Thrissur played an active role in mobilizing 1413 participants.



Special address by Dr. S. Jaishankar, Hon'ble Minister of External Affairs



Shri. G.S. Prakash, JD & HoO MSME-DFO, Thrissur lightning the lamp



View of the participants

- On 17.09.2023 MSME DFO, Thrissur coordinated with Southern Railways for organizing the Programme at Vinayaka Hall, Ernakulam. MSME-DFO, Thrissur played an active role in mobilizing 1021 participants.



Shri. D. Kuppuramu, Chairman of Coir Board inaugurated the programme



The Audience

- On 17.09.2023 MSME DFO, Thrissur coordinated with Directorate of Industries, UT of Lakshadweep for organizing the Programme at Multipurpose Hall, Secretariat, Kavaratti. MSME-DFO, Thrissur played an active role in mobilizing 150 participants.



*Inaugural Address by Smt. Darshana Vikram Jardosh,
MoS, Railways*



The Audience

4.3. State Level Workshops and District Level Awareness Programmes

As per the instructions of O/o DC (MSME), MSME-DFO, Thrissur has organised 14 District Level Awareness Programmes and 3 State Level Workshops (1 Online) in the State of Kerala and UT of Lakshadweep. Details of those programmes are shown in the following sections.

4.3.1. i. State Level Workshops at Thiruvananthapuram

MSME-Development & Facilitation Office Thrissur organized State Level Workshop on PM Vishwakarma on 4th January 2024 at Hotel Residency Tower, Thiruvananthapuram. The programme was inaugurated by Shri.Saurabh Jain, IAS Secretary Govt of Kerala (Labour, Skill & Industries). Shri.G.S.Prakash, IEDS Joint Director & Head of Office, MSME-DFO, Thrissur delivered a detailed presentation on PM Vishwakarma Scheme. Shri.SuvidVijayan, CSC-Kerala State Head & Shri.Vishnu, District Manager, CSC-Kerala, Thiruvananthapuram explained about the on boarding procedures of beneficiaries in the portal. Stage 1 verification/role of LSGD was explained by Shri.Rajiv, Joint Director LSGD Palakkad. Stage 2 verification/ role of DIC's in the scheme was explained by Dr.K.Kripakumar, Additional Director, Directorate of industries & Commerce, Govt of Kerala. Verification of financial credentials in the application submitted by the beneficiaries was explained by Shri.AchuthSankar, Senior Manager, SLBC. Role of RDSDE and skill training was delivered in detail by Shri.H.C.Goyal, ISDS, Regional Director & Dr.Mahesh, Additional Director, Department of Training, Govt of Kerala. Shri.Nikhil Pramod, Regional Officer, KADCO being the implementing agency explained the role of KADCO. The programme was followed by detailed interaction and Q&A session. The interaction was moderated by Shri.G.S.Prakash. The programme got concluded by 02.00PM, which was attended by 78 officials from DIAC, District Industries Centre, LSGD's, CSC Centres, SLBC, Banks, KADCO, RDSDE etc.



Presentation of PM Vishwakarma scheme by Shri.G.S.Prakash, Joint Director & Head of Office, MSME-DFO, Thrissur

4.3.1. ii. State Level Workshop at Thrissur

MSME Development & Facilitation Office, Thrissur organized State Level Workshop on PM Vishwakarma on 7th March, 2024 at MSME-DFO, Thrissur. The Registration started at 10.30 am to 11 am. Shri Vishesh Aggarwal, Assistant Director, MSME-DFO, Thrissur welcomed the gathering and Shri.G.S.Prakash, Joint Director & HoO, MSME-DFO, Thrissur presented the Agenda among the participants. Review on PM Vishwakarma Scheme was held. Shri.G.S.Prakash, JD/HoO & Shri Vishesh Aggarwal, AD gave an overall status report to the gathering and explained the latest statistics as well as the latest changes, field level experiences, mechanism for resolution of queries as well do's and don'ts for optimum results while registration. After that a panel discussion was held with the following members as panellists:

- a) Shri Khalid Muhsin, District Manager CSC Palakkad - CSC
- b) Shri Jai P Bal, Deputy Director, LSGD – Tier I
- c) Dr. Kripa Kumar, Additional Director, DIAC, Government of Kerala/ GM DICs – Tier II
- d) Shri Mohanachandran, LDM Thrissur – Bank/SLBC
- e) Shri.G.S.Prakash, JD & HoO, MSME-DFO, Thrissur – Tier III

After the deliberations a Vote of Thanks was delivered by Shri Vishesh Aggarwal, Assistant Director, MSME DFO, Thrissur and then the Workshop concluded with Lunch at 3 pm, which was attended by more than 100 officials from DIAC, District Industries Centre, LSGDs, CSC, SLBC, and Officers and Officials of MSME DFO, Thrissur.



Dr. Kripa Kumar, Additional Director, DIAC, Government of Kerala inaugurated the Workshop



Shri. G.S.Prakash, JD/HoO of MSME-DFO, Thrissur handling the queries

4.3.1 iii. Online Workshop on PM Vishwakarma for Lakshadweep

Online Workshop on PM Vishwakarma for Lakshadweep was organized in association with the Industries Department, UT of Lakshadweep on 14th March, 2024. Officials from various Line Departments in Lakshadweep, Officials from SLBC, Ministry of Skill Development, CSC, LDM etc. attended the deliberations. The whole scheme was explained to the gathering step by step and it was suggested to enrol the respective executives as First level approving authority. The Workshop was attended by almost 70 participants.

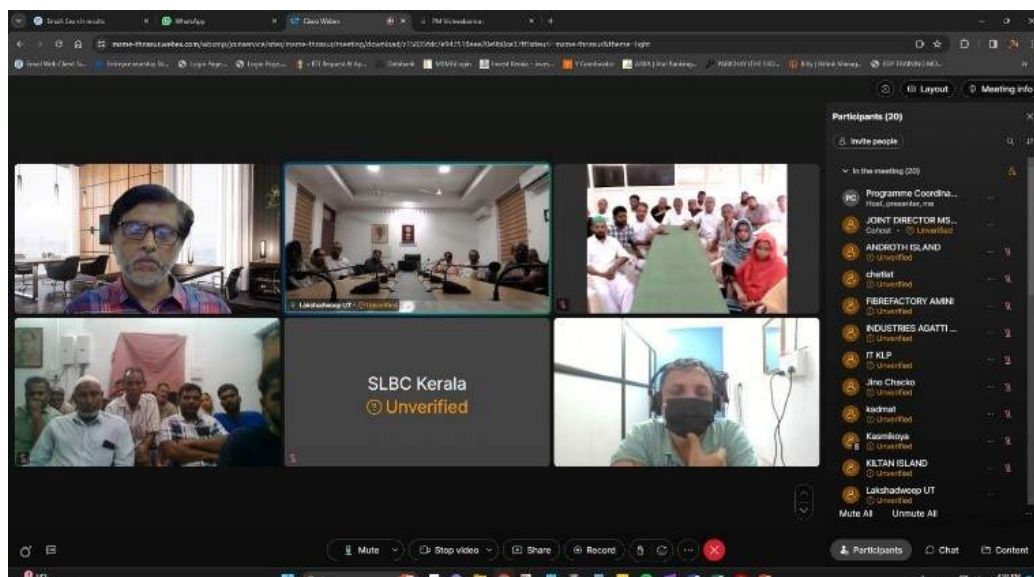

Screenshot of the Meeting

4.3.2. District Level Seminars conducted by MSME DFO, Thrissur

As per the sanctions of O/o DC(MSME), MSME-DFO, Thrissur has organised District Level Programmes in all the Districts with massive participation of Stakeholders. The brief reports of programmes in each District are as follows:

4.3.2.1. Thrissur District

Thrissur District Seminar cum Awareness programme on PMVK was organized at Regional Theatre, Chembukkavu, Thrissur on 28/12/2023. Smt. Rekha K., Assistant Director, MSME-DFO, Thrissur delivered the welcome address. Shri.KrishnaTeja, IAS Thrissur District Collector and Chairman of District Level Committee inaugurated the programme. The main presentation on PM Vishwakarma was done by Shri G S Prakash IEDS, Joint Director & HoO, MSME-DFO, Thrissur. Presentation on onboarding of applications was done by District level CSC Coordinator. Stage 1 verification process is explained by Shri. Sidheek , Deputy Director, Local Self Government Department, Govt of Kerala, Thiruvananthapuram District. Stage 2 verification process is explained by General Manager, District Industries Centre, Smt. Sheeba S. Verification process of financial institution was explained by Smt. Sunitha Ramesh, Senior Manager, Canara Bank, Regional Office, Thrissur representing Lead District Manager, Thrissur. Thereafter, a panel of officers including Joint Director, MSME-DFO, Thrissur, Joint Director LSGD, General Manager, DIC, LDM/Manager from Bank answered the queries raised by the participants. 3 nos. of Registration counters were arranged and the drive was continued during the afternoon after lunch. 600 participants attended the programme.



Presidential address by Shri. G.S. Prakash, JD & HoO, MSME-DFO, Thrissur



Inaugural address by Shri. Krishna Teja, IAS Thrissur District Collector



Panel of officers



From Q&A Session



View of Participants

4.3.2.ii Kottayam District

Kottayam District Seminar cum Awareness Programme on PMVK was organized at Kottayam – KPS Menon Auditorium, Kottayam on 08.01.2024. Shri P.B. Suresh Babu, IEDS, Asstt. Director, MSME Development & Facilitation Office, Thrissur delivered welcome address. Shri.G.S.Prakash, IEDS, Joint Director & HoO, MSME-DFO, Thrissur MSME- Development and Facilitation Office, Thrissur

presided over the function. Smt. V. Vigneshwari, IAS, Kottayam District Collector and Chairman of District Level Committee inaugurated the programme. The main presentation on PM Vishwakarma was done by Shri.G.S.Prakash, IEDS, Joint Director & HoO, MSME-DFO, Thrissur. Presentation on on-boarding of applications was done by Shri. Jithin J. Nair, Kottayam District Level CSC Coordinator. Stage-II verification and approval procedure was explained by District Committee Convener - Ms. Lovely, General Manager, District Industries Centre, Kottayam. Shri Alex E.M., Lead District Manager, Kottayam, elaborated the role of commercial bank in implementation Scheme. Thereafter, a panel of officers including Joint Director, MSME DFO, Thrissur, General Manager, DIC, and LDM etc. answered the queries raised by the participants. Registration counters were arranged and the drive was continued during the afternoon after lunch. 500 participants attended the programme.



Welcome address by Shri. P.B. Sureshbabu Asst. Director and Programme Coordinator, MSME-DFO, Thrissur



Inaugural address by Smt. V. Vigneshwari, IAS, Kottayam District Collector



View of Participants



From Registration Drive

4.3.2.iii. Malappuram District

Malappuram District Seminar cum Awareness programme on PMVK was organized at Kunnummal Variyam Kunnath Kunju Mohammed Haji Memorial Auditorium, Malappuram on 09.01.2024. Smt.Safoora M A Assistant Director, MSME-DFO, Thrissur delivered the welcome address. Shri.G.S.Prakash, IEDS, Joint Director and HoO, MSME-DFO, Thrissur inaugurated the programme. The main presentation on PM Vishwakarma was done by, Shri.G.S.Prakash, IEDS, Joint Director and HoO MSME-DFO, Thrissur. Presentation on onboarding of applications was done by Shri.Noushad K P, District Manager of CSC, Malappuram. Stage 1 verification process is explained by Shri.Byju P, Assistant Director, LSGD Malappuram District. Stage 2 verification process is explained by Shri. Sojan C R, Deputy Director, District Industries Centre, Malappuram. Verification process of financial institution was explained by Shri. Shinod C P, Senior Manager – Canara Bank representing Lead District Manager, Malappuram. Thereafter, a panel of Officers including Joint Director MSME-DFO, Thrissur, Assistant Director LSGD, Deputy Director, DIC, LDM/Manager from Bank answered the queries raised by the participants. 10 nos. of Registration counters were arranged and the drive was continued during the afternoon after lunch. 600 participants attended the programme.

	
<p><i>Welcome address by Smt. Safoora M.A., Asst. Director and Programme Coordinator, MSME-DFO, Thrissur</i></p>	<p><i>Panel of Officers</i></p>



4.3.2.iv. Ernakulam District

Ernakulam District Seminar cum Awareness programme on PMVK was organized at Ernakulam Town Hall on 10.01.2024. Smt. Lachithamol U.C. Asst. Director, MSME-DFO, Thrissur delivered the welcome address. Shri.NSK Umesh IAS, Ernakulam District Collector and Chairman of District Level Committee inaugurated the programme. The presentation on PM Vishwakarma was done by Shri.G.S.Prakash, IEDS, Joint Director &HoO, MSME-DFO, Thrissur. Presentation on onboarding of applications was done by District level CSC Coordinator. Stage 1 verification process is explained by Joint Director, LSGD, Ernakulam. Stage 2 verification process is explained by General Manager, District Industries Centre, Ernakulam. Verification process of financial institution was explained by Manager, Union Bank of India representing Lead District Manager, Ernakulam. Thereafter, a panel of officers including Joint Director, MSME-DFO, Thrissur, Joint Director LSGD, General Manager, DIC, LDM/Manager from Bank answered the queries raised by the participants. 10 Registration counters were arranged and the drive was continued during the afternoon after lunch. 800 participants attended the programme.



Presidential address by Shri. G.S. Prakash, JD & HoO, MSME-DFO, Thrissur



Inaugural address by Shri.NSK Umesh IAS, Ernakulum District Collector



Panel of officers



From Q&A Session



From Registration Drive



View of Participants

4.3.2.v. Kannur District

Kannur District Seminar cum Awareness programme on PMVK was organized at Jawaharlal Public Library, Talap, Kannur on 11.01.2024. Martin P. Chacko Assistant Director, MSME- DFO, Thrissur delivered the welcome and presidential address. The main presentation on PM Vishwakarma was done by Shri Martin P. Chacko, MSME-DFO, Thrissur. Presentation on onboarding of applications was done by District level CSC Coordinator. Stage 1 verification process is explained by Shri. Dhaneesh, Dy. Director, LSGD, Kannur District. Stage 2 verification process is explained by Shri RajanK. Dy. Registrar, District Industries Centre, Kannur. Verification process of financial institution was explained by Shri. Prashanth E, representing Lead District Manager, Kannur. Thereafter, a panel of officers of MSME-DFO, Thrissur, DIC, Kannur, LSGD-Kannur, LDM answered the queries raised by the participants. 10 nos. of Registration counters were arranged and the drive was continued during the afternoon after lunch. 650 participants attended the programme.



*Presidential address by Shri. Martin P. Chacko,
Asst. Director and Programme Coordinator,
MSME-DFO, Thrissur*



From Technical Sessions



From Registration Drive



View of Participants

4.3.2.vi. Kasaragod District

Kasaragod District Seminar cum Awareness programme on PMVK was organized at Municipal Town Hall Kasaragod on 13.01.2024. Shri Martin P. Chacko Assistant Director, MSME-DFO, Thrissur delivered the welcome and presidential address. The main presentation on PM Vishwakarma was done by Shri Martin P. Chacko, MSME-DFO, Thrissur. The programme was inaugurated by Shri Dileep K. Kainikkara, IAS, Assistant Collector, Kasaragod district. Presentation on onboarding of applications was done by District level CSC Coordinator. Stage 1 verification process is explained by Smt. Manjusha, Asstt. Director, LSGD, Kasaragod District. Stage 2 verification process is explained by Shri Sajith Kumar, GM, DIC, Kasaragod. Verification process of financial institution was explained by LDO representing Lead District Manager, Kasaragod. Thereafter, a panel of officers of MSME-DFO, Thrissur, DIC, Kasaragod, LSGD-Kasaragod, LDO answered the queries raised by the participants. 15 nos. of Registration counters were arranged and the drive was continued during the afternoon. 720 participants attended the programme.



Inaugural address by Shri Dileep K. Kainikkara, IAS, Assistant Collector, Kasaragod District



Panel of officers



View of Participants

4.3.2.vii. Idukki District

Idukki District Seminar cum Awareness programme on PMVK was organized at Merchants Trust Hall Thodupuzha on 16.01.2024. Shri. Vishesh Aggarwal, Assistant Director, MSME-DFO, Thrissur delivered the welcome address. Shri Shaiju Jacob, ADM, Idukki inaugurated the programme. The main presentation on PM Vishwakarma was done by Shri.G.S.Prakash, IEDS, Joint Director & HoO, MSME-DFO, Thrissur. Presentation on onboarding of applications was done by District level CSC Coordinator. Stage 1 verification process is explained by Shri Joseph Sebastian, Deputy Director, LSGD, Idukki District. Stage 2 verification process is explained by Shri Sahil Muhammad, General Manager, District Industries Centre, Idukki. Verification process of financial institution was explained by Shri Jose Mathew, Branch Manager, SBI Muttom representing Lead District Manager, Idukki. Thereafter, a panel of officers from MSME-DFO, Thrissur including JD & HoO, DD LSGD, General Manager, DIC, Branch Manager from SBI, District CSC Coordinator answered the queries raised by the participants. 10 nos. of Registration counters were arranged and the drive was continued during the afternoon after lunch. 350 participants attended the programme.

	
<p><i>Presidential address by Shri. G.S. Prakash, JD & HoO, MSME-DFO, Thrissur</i></p>	<p><i>Inauguration by Shri Shaiju Jacob, ADM, Idukki</i></p>
	
<p><i>Panel of officers</i></p>	<p><i>View of Participants</i></p>

4.3.2.viii. Thiruvananthapuram District

Thiruvananthapuram District Seminar cum Awareness programme on PMVK was organized at Pattom Thanu Pillai Priyadarshini Hall, Thiruvananthapuram on 19/01/2024. Smt. Rekha, Assistant Director, MSME-DFO, Thrissur delivered the welcome address. Shri. Vivek Menon, IAS, Assistant Collector, Thiruvananthapuram inaugurated the programme. The main presentation on PM Vishwakarma was done by Shri G.S.Prakash, IEDS, Joint Director & HoO, MSME-DFO, Thrissur. Presentation on onboarding of applications was done by District level CSC Coordinator. Stage 1 verification process is explained by Shri. Jyothis. V, Assistant Director, LSGD. Stage 2 verification process is explained by Shri by Shri. Ajith, General Manager, District Industries Centre. Verification process of financial institution was explained by Shri.Jayamohan, LDM. Thereafter, a panel of officers from MSME-DFO, Thrissur including JD & HoO, DD LSGD, General Manager, DIC, Branch Manager from SBI, District CSC Coordinator answered the queries raised by the participants. 10 nos. of Registration counters were arranged and the drive was continued during the afternoon after lunch. 700 participants attended the programme.



Welcome Address by Smt. K. Rekha, Asst. Director and Programme Coordinator, MSME-DFO, Thrissur



Inaugural address by Shri.Vivek Menon IAS, Assistant Collector, Thiruvananthapuram

	
<p><i>Panel of officers</i></p>	<p><i>From Q&A Session</i></p>
	
<p><i>From Registration Drive</i></p>	<p><i>View of Participants</i></p>

4.3.2.ix. Kozhikode District

Kozhikode District Seminar cum Awareness programme on PMVK was organized at Nalanda Auditorium, Kozhikode on 20.01.2024. Shri Vishesh Aggarwal, Assistant Director, MSME- DFO, Thrissur delivered the welcome address. Shri. Prateek Jain, IAS, Assistant Collector, Kozhikode District inaugurated the programme. The main presentation on PM Vishwakarma was done by Shri Martin P Chacko, IEDS, Assistant Director of MSME-DFO, Thrissur. Presentation on onboarding of applications was done by Shri Nigesh M K, District level CSC Coordinator. Stage 1 verification process is explained by Smt. Najila Ubaidulla, Empowerment Officer, O/o Joint Director, LSGD, Kozhikode District. Stage 2 verification process is explained by Shri Anand Kumar K T, Manager, District Industries Centre, Kozhikode. Verification process of financial institution was explained by Smt. Jeeshma T K, Loan Section Manager, Kerala Bank Kozhikode Region representing Lead District Manager, Kozhikode. Thereafter, a panel of officers from MSME-DFO, Thrissur including JD & HoO, LSGD, Manager, DIC, Branch Manager from

Kerala Bank, District CSC Coordinator answered the queries raised by the participants. 10 nos. of Registration counters were arranged and the drive was continued during the afternoon after lunch. 600 participants attended the programme.



Welcome Address by Shri. Vishesh Aggarwal, Asst. Director and Programme Coordinator, MSME-DFO, Thrissur



Inaugural address by Shri. Prateek Jain, IAS, Assistant Collector, Kozhikode District



From Registration Drive



From Q&A Session



View of Participants

4.3.2.x. Kollam District

Kollam District Seminar cum Awareness programme on PMVK was organized at Kollam Public Library Hall (Sopanam Auditorium) on 20.01.2024. Smt. Lachithamol U.C., Assistant Director, MSME-DFO, Thrissur delivered the welcome address. Shri. Mukund Thakur IAS, Sub Collector of Kollam, inaugurated the programme. The main presentation on PM Vishwakarma was done by Shri.G.S.Prakash IEDS, Joint Director & HoO, MSME-DFO, Thrissur. Presentation on onboarding of applications was done by Shri. Muhammad Arshad, CSC District Manager, Kollam District. Stage 1 verification process is explained by Smt. Anu C.S., Senior Supdt, LSGD, Kollam District. Stage 2 verification process is explained by Shri. Biju Kurian, GM, District Industries Centre, Kollam. Verification process of financial institution was explained by Ms. Arunima V.T., LDM, Kollam. Thereafter, a panel of officers Joint Director of MSME-DFO, Thrissur, Senior Office Supdt of LSGD, General Manager, DIC, LDM, CSC District Coordinator answered the queries raised by the participants. 25 nos. of Registration counters were arranged and the drive was continued in the afternoon after lunch. 700 participants attended the programme.



Welcome Address by Smt. Lachithamol U.C., Asst. Director and Programme Coordinator, MSME-DFO, Thrissur



Inaugural address by Shri. Mukund Thakur IAS, Sub Collector of Kollam



Panel of officers



From Q&A Session



From Registration Drive



View of Participants

4.3.2.xi. Alappuzha District

Alappuzha District Seminar cum Awareness programme on PMVK was organized at E M S Community Hall, North Punnapra, Alappuzha on 23.01.2024. Smt. Safoora M A Assistant Director, MSME-DFO, Thrissur delivered the welcome address. Shri. Sameer Kishan IAS, Alappuzha District Sub Collector inaugurated the programme. The main presentation on PM Vishwakarma was done by, Shri.G.S.Prakash IEDS, Joint Director and HoO MSME-DFO, Thrissur. Presentation on onboarding of applications was done by Shri. Kiran K, CSC State Project Manager. Stage 1 verification process is explained by Shri. Alex, Deputy Director, LSGD Alappuzha District. Stage 2 verification process is explained by Shri. Manoj V P, General Manager, District Industries Centre, Alappuzha. Verification process of financial institution was explained by Shri. Anandu, Senior Manager- Canara Bank representing Lead District Manager, Alappuzha. Thereafter, a panel of Officers including Joint Director MSME-DFO, Thrissur, Assistant Director LSGD, Deputy Director, DIC, LDM/Manager from Bank answered the queries raised by the participants. 10 nos. of Registration counters were arranged and the drive was continued during the afternoon after lunch. 400 participants attended the programme.



Presidential address by Shri. G.S. Prakash, JD & HoO, MSME-DFO, Thrissur



Inaugural address by Shri. Sameer Kishan IAS, Alappuzha District Sub Collector



Panel of officers



From Q&A Session



From Registration Drive



View of Participants

4.3.2.xii. Palakkad District

Palakkad District Seminar cum Awareness programme on PMVK was organized at Jilla Panchayath Hall, Palakkad on 27.01.2024. Shri Martin P. Chacko Assistant Director, MSME- DFO, Thrissur delivered the welcome and presidential address. The main presentation on PM Vishwakarma was done by Shri. Martin P. Chacko, MSME-DFO, Thrissur. Presentation on onboarding of applications was done by District level CSC Coordinator. Stage 1 verification process is explained by Shri. Raviraj, Joint Director, LSGD, Palakkad District. Stage 2 verification process is explained by Shri Basheer, Dy. Registrar, DIC, Palakkad. Verification process of financial institution was explained by Div. Manager, Canara Bank, Palakkad representing office of LDM, Palakkad. Thereafter, a panel of officers of MSME-DFO, Thrissur, DIC, Palakkad, LSGD-Palakkad, Div. Mgr. Canara Bank, Palakkad answered the queries raised by the participants. 12 nos. of Registration counters were arranged and the drive was continued during the afternoon hrs and could attend 85 registrations. 606 participants attended the programme.



Presidential address by Shri. Martin P. Chacko, AD and Programme Coordinator, MSME-DFO, Thrissur



From Technical Sessions



4.3.2.xiii. Pathanamthitta District

Pathanamthitta District Seminar cum Awareness Programme on PMVK was organized at Aban Auditorium, Pathanamthitta on 31.01.2024. Shri Suresh Babu, IEDS, Asst. Director, MSME DFO, Thrissur and District Program Coordinator welcomed the gathering. Shri. G.S.Prakash, IEDS, Joint Director and HoO, MSME-DFO, Thrissur presided over the meeting. The program was inaugurated by Shri. A.Shibu, IAS, District Collector, Pathanamthitta. A detailed session on PM Vishwakarma Yojana presented by the Shri G.S.Prakash, IEDS, Joint Director & HoO, MSME DFO, Thrissur. Stage-I verification of online applications and the PM Vishwakarma Yojana and the role of Local Self Government is explained by Smt. Vineetha Soman, District Empowerment Officer, LSD Department, Pathanamthitta District. Stage-II verification and approval procedure of PM Vishwakarma Yojana applicants was explained by Shri. Anil Kumar P.N., General Manager District Industries Centre, Pathanamthitta and District Committee Convener – PM Vishwakarma, Pathanamthitta. The stage by stage registration procedure of the beneficiaries as explained by Shri Gopal Prasad, District Manager, Common Service Centre. Banking credentials and role of schedule banks in the PM Vishwakarma Yojana was explained by Shri Syriac Thomas, Lead District Manager, Pathanamthitta. Thereafter, a panel of officers including Joint Director, MSME DFO, Thrissur, General Manager District Industries Centre, Pathanamthitta and District Committee Convener – PM Vishwakarma, Pathanamthitta, District Empowerment Officer, LSD Department, Pathanamthitta, Lead District Manager, Pathanamthitta etc. answered the queries raised by the participants. Registration counters were arranged and the drive was continued during the afternoon after lunch. 480 participants attended the programme.



Presidential address by Shri. G.S. Prakash, JD & HoO, MSME-DFO, Thrissur



Inaugural address by Shri. A. Shibu, IAS, District Collector, Pathanamthitta



Panel of officers



From Q&A Session



From Registration Drive



View of Participants

4.3.2.xiv. Wayanad District





Wayanad District Seminar cum Awareness Programme on PMVK was organized at Lalith Mahal Auditorium, Kalpetta, Wayanad. Shri P.B. Suresh Babu, IEDS, Asstt. Director & CDO, MSME-DFO, Thrissur welcomed the participants. Wayanad Sub Collector Shri Misal Sagar Bharat, IAS inaugurated the program. MSME-DFO, Joint Director & Head of Office- Shri.G.S.Prakash, IEDS presided over function. The main presentation on PM Vishwakarma Yojana was done by Shri G.S.Prakash, IEDS, Joint Director & HoO, MSME DFO, Thrissur. Stage-I verification of Application/ Role of Local Self-Government Department were explained by Mr. Benny Joseph, Local Self-Government Department, Wayanad District. Regarding the Stage-II inspection and approval, District Committee Convener Mrs. Lisamma, General Manager District Industries Centre, Wayanad explained. Shri. Vishnu Ravindran, District Manager, Common Service Center Wayanad explained about the registration on PM Vishwakarma portal- step by step process. Shri. Cyvin Vincent P. Branch Manager, Kolagappara Branch, Wayanad District spoke about verification of banking credentials and role of banks in PM Vishwakarma scheme. Thereafter, a panel of Officers including joint Director, MSME DFO, Thrissur, GM, DIC, Wayanad, Representative from LSGD Department, District Manager – CSC, Branch Manager-SBI, Kolagapara etc. answered the queries raised by the participants. The program concluded with a question and answer session. 10 Nos. of Registration counters were arranged and the drive was conducted during the afternoon (after lunch). 422 participants attended the programme.



Presidential address by Shri. G.S. Prakash, JD & HoO, MSME-DFO, Thrissur



Inaugural address by Shri Misal Sagar Bharat, IAS, Sub Collector, Wayanad

	
<p><i>Address by Shri. P.B. Sureshabu, Asst. Director and Programme Coordinator, MSME-DFO, Thrissur</i></p>	<p><i>From Q&A Session</i></p>
	
<p><i>From Registration Drive</i></p>	<p><i>View of Participants</i></p>

4.4. Status of Implementation of PM Vishwakarma in the State

- Total number of registrations under PM Vishwakarma 40678
- Total number of beneficiaries recommended after Stage 3 verification 12197
- Shri. Vishesh Aggarwal, Assistant Director (Statistics), along with 3 Artisans from Kozhikode, Wayanad and Idukki and spouse of one of the Artisans visited Delhi to attend the Independence Day Celebration 2023 at Red Fort. The four individuals were invited as “Special Invitee” to the Honourable PM of India to attend the Independence Day celebrations.



Photograph of Artisans from Kerala at Red Fort

- Shri. Vishesh Aggarwal, Assistant Director(Statistics), along with 3 Artisans from Kozhikode, Alappuzha and Ernakulam visited Delhi to attend the Inaugural Ceremony of PM Vishwakarma on 17th September, 2024 and the Boatmaker Artisan Shri Peter K V also received the first PM Vishwakarma Certificate and ID Card directly from the Honourable Prime Minister. The three individuals were invited as “Special Invitee” to the Honourable PM of India.



Photograph of Shri Peter K V receiving PM Vishwakarma Certificate from Hon'ble PM

- On occasion of the inauguration of PM Vishwakarma scheme at New Delhi by Honourable Prime Minister on 17/9/2023, this office was tasked with arranging a model of traditional boat for an exhibition as part of the inauguration. Accordingly M/s A One Wood Industries which is implementing a CFC project in the Zamorian wood cluster, Kozhikode was contacted and accordingly a boat

(Traditional Beypore Model) was transported to New Delhi for the Exhibition.



Team from Kerala with the Boat taken to New Delhi for Displaying in the Exhibition as part of PM Vishwakarma Scheme Inauguration

- As per the instructions of O/o DC(MSME), four PM Vishwakarma Artisans pertaining to different trades along with their spouse were selected from the beneficiaries who cleared Tier III verification under PM Vishwakarma to attend the Republic Day celebration 2024 at New Delhi as special invitee of Honourable PM under the supervision of Shri. Vishesh Aggarwal, Assistant Director(Statistics).



Republic Day Special Invitees at New Delhi

Chapter 5

Champion MSMEs and Innovation

5.1 Introduction on MSME Champions Scheme (Erstwhile CLCS-TUS)

Ministry of MSME has been implementing Credit Linked Capital Subsidy and Technology Up gradation Scheme (CLCS-TUS) for promoting competitiveness amongst MSMEs by the way of wastage reduction through Lean Manufacturing, support for Design improvement, building awareness on Intellectual Property Rights, Zero Defect Zero Effect (ZED) Scheme, digital empowerment of MSME through Digital MSME and to promote & support untapped creativity of individual and to promote adoption of latest technologies in manufacturing as well as knowledge based innovation MSMEs through Incubation across India.

MSME Champions scheme has been by merging all six components of erstwhile Technology Up gradation Scheme (TUS) for a period of 5 years i.e 2021-22 to 2025-26. It is a Holistic Approach to unify, synergize and converge various schemes and Interventions with a single purpose. The end objective is to enhance the competitiveness of enterprises through adoption of best processes, reduce wastages, sharpening business competitiveness and facilitate their National and Global reach and excellence. There are three components under the modified MSME Champions scheme, the details of which are as below:

1. MSME-Sustainable(ZED)
2. MSME-Competitive(Lean)
3. MSME-Innovative(for Incubation, IPR, Design and Digital MSME)

5.2 MSME Sustainable ZED Scheme

MSME Sustainable (ZED) Certification is an extensive drive to create awareness amongst MSMEs about Zero Defect Zero Effect (ZED) practices and motivate & incentivize them for ZED Certification while also encouraging them to become MSME Champions. Through the journey of ZED Certification, MSMEs can reduce wastage substantially, increase productivity, enhance environmental consciousness, save energy, optimally use natural resources, expand their markets, etc. MSMEs will also be motivated to adopt best practices in work culture, standardization of products, processes, systems etc. in order to enhance their global competitiveness and sustainability.

Table 5.1: Assistance under MSME Sustainable ZED Scheme

Nature of assistance	Cost of Certification
	a) Certification Level1:BRONZE:Rs.10,000/-
	b) Certification Level2:SILVER:Rs.40,000/-
	c) Certification Level3:GOLD:Rs.90,000/-

Subsidy on cost of ZED certification:	<ul style="list-style-type: none"> • Joining Reward of Rs.10,000/- (Bronze will become free if availed) • 80-60-50% for Bronze, Silver & Gold ZED certified MSMEs • 100% for Women ZED certified MSMEs
Additional subsidy:	<ul style="list-style-type: none"> • 10% for SC/ST owned MSMEs OR MSMEs in NER/Himalayan/LWE/Island territories/Aspirational districts • 5% for MSMEs that are also a part of the SFURTI or Micro & Small Enterprises – Cluster Development Programme (MSE-CDP) of the Ministry
Financial Assistance in Testing/Quality/Product Certification:	<ul style="list-style-type: none"> • Up to 75% of the total cost of Testing/Certification, with the maximum ceiling of subsidy being Rs. 50,000/-
Handholding/Consultancy Support:	<ul style="list-style-type: none"> • Up-to Rs.2 lakh for handholding/Consultancy in Order to achieve the next Certification Level.
Support in Technology Up gradation for Zero Effect Solutions:	<ul style="list-style-type: none"> • Up-to Rs. 3 lakhs for moving towards zero effect solutions/pollution control measures/cleaner Technology
Graded incentives:	<ul style="list-style-type: none"> • MSMEs can avail graded incentives as prescribed for the three ZED Certification Levels. Wherever possible, the incentives provided by States will be linked through API integration with the ZED portal • To ensure interoperability.
Eligibility/Applicability:	<ul style="list-style-type: none"> • All MSMEs registered with the UDYAM registration portal (of the MoMSME) will be eligible to participate in MSME Sustainable (ZED) Certification and can avail related benefits/incentives.
How to Apply:	<ul style="list-style-type: none"> • Eligible MSMEs shall apply through online portal Email: https://zed.msme.gov.in/

5.2.1 Status of Implementation of MSME Sustainable (ZED) Certification scheme in Kerala

Table 5.2: Status of Scheme Implementation

Component	Cumulative As on 31.03.2024
No: of ZED registrations	3898
Bronze ZED certified	2466
Silver ZED certified	8

Gold ZED certified	9
No:of awareness programmes Conducted if any	1 Webinar; 14 Physical Programmes
Total no: of participants trained	3000

5.2.2 Online Awareness Programme on ZED & LEAN for the Govt of Kerala Officers

MSME-DFO, Thrissur and Directorate of Industries & Commerce Govt. of Kerala organized virtual online workshop exclusively for District Industries Centre Officials on 30th June 2023 from 02.30PM-04.30 PM. The programme was inaugurated by Dr.Suman Billa, IAS, Principal Secretary (Industries), Govt of Kerala. Special address was delivered by Shri.Harikishore, IAS, Director, DIAC, Govt of Kerala. Shri.G.S.Prakash, Joint Director & Head of Office, Thrissur, MSME-DFO, Thrissur delivered the introductory remarks and brief presentation about MSME Sustainable ZED Scheme and MSME Competitive Lean Scheme. Shri.Jayakumar.M.M, Chairman & Managing Director, M/s. Sowparnika Thermistors & Hybrids Pvt Ltd. (National MSME Award Winner 2022-Manufacturing) shared experience of obtaining Gold ZED certification.

Shri.Karthikeyan, ZED Assessor by QCI and Managing Director, M/s. Quest Certification (P) Limited, Chennai & Shri.Vinod Khannoth, Technical Consultant of Lean explained on how ZED & Lean help to improve competitiveness of MSMEs. Introduction to ZED Certification Scheme, Registration Procedure, Benefits & Incentives was explained by Smt.RekhaK., Assistant Director (Chemical), MSME- DFO, Thrissur. Services offered for ZED certification by Empanelled Consulting Organization from Kerala was explained by Shri.K.M.Shanavaz, Joint Director, Kerala State Productivity Council, Ernakulam & ZED Consultant by QCI. The programme was attended by 370 District Industries Centre's officials.

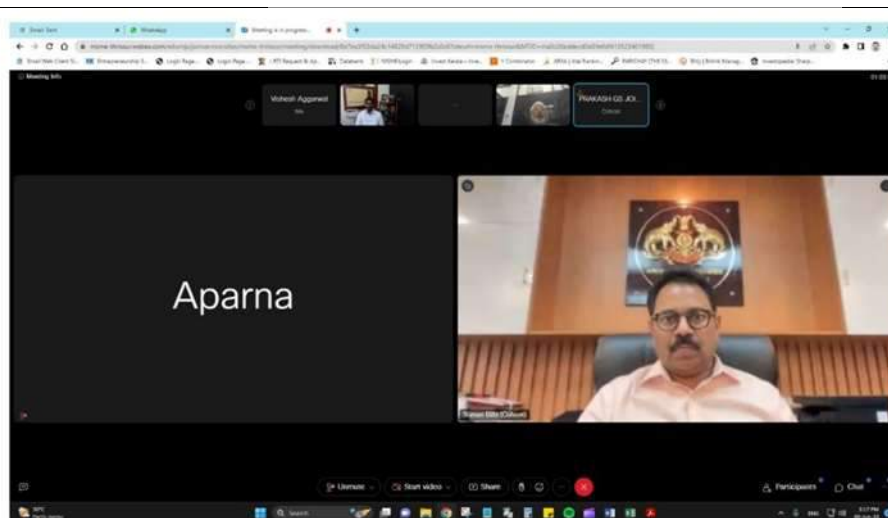

Dr.Suman Billa, IAS, Principal Secretary (Industries) attending the virtual awareness programme on ZED organized on 30th June 2023 by MSME-DFO, Thrissur in association with DIAC for DIC officials

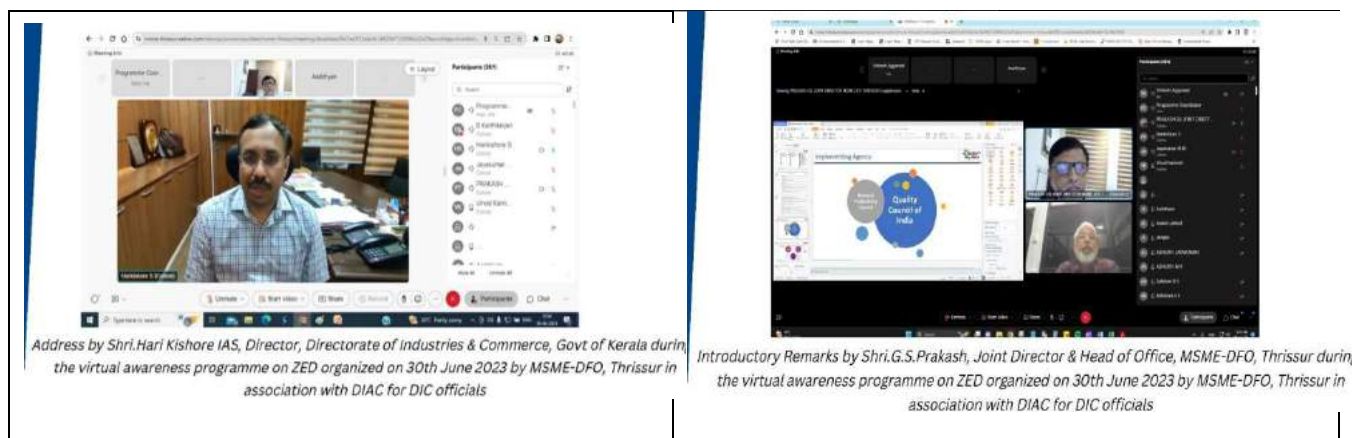

5.3. MSME Competitive (LEAN) Scheme

MSME Competitive (Lean) Scheme is an extensive drive on the part of Ministry of Micro, Small and Medium Enterprises for enhancing the competitiveness of MSME Sectors through implementation of Lean Tools and Techniques. Lean Tools and Techniques are a tested and proven methodology for improving the competitiveness of MSME sector.

Nature of assistance	Cost of Implementation: Basic-Free; Intermediate- Rs. 1,20,000/-; Advance- Rs. 2,40,000/-
Financial Assistance to group of MSME Units for adoption of Lean tools/techniques	Subsidy on cost of Implementation: 90% of Total Cost of Implementation
Eligibility/ Applicability	All MSMEs registered with the UDYAM registration portal of M/o MSME) will be eligible to participate in MSME- COMPETITIVE (LEAN) and avail related benefits/incentives.

5.3.1. Awareness Programmes on LEAN

Micro, Small and Medium Enterprises - Development and Facilitation Office, Thrissur, organized physical Awareness Programme on LEAN as per the Development Commissioner (MSME)'s sanction order. The following table shows the details of the programmes organized.

Table 5.3: Details of the Awareness Programme on LEAN

Sl No	Venue	Programme ID	Date	No: of Participants	Total Expenditure (Rs.)
1	KINFRA Apparel Park, Thiruvananthapuram	LEANAP200	12/01/24	56	67642
2	RECCAA CLUB, Kakkanad, Kochi	LEANAP227	25/01/24	63	69007
3	Indian Chamber of Commerce & Industry Hall, Mattancherry, Kochi	LEANAP241	02/02/24	51	56328
4	Hotel Tilak, Near KSRTC, Thiruvalla	LEANAP282	28/02/24	58	69758
5	MSME-DFO, Thrissur	LEANAP286	28/02/24	66	70000
6	KSSIA Hall, Kalamassery, Ernakulam	LEANAP1302	29/02/24	50	69652
7	MSME-DFO, Thrissur	LEANAP284	06/03/24	146	70000
8	North Malabar Chamber of Commerce, Kannur	LEANAP349	14/03/24	77	69910
Total		Pledges taken-84		567	542297

Brief reports of the awareness programmes are as follows:

5.3.1.i Awareness Programme at Thiruvanthapuram on 12.01.2024

MSME-DFO, Thrissur in association with KINFRA Entrepreneurs Association Thiruvananthapuram organized awareness programme on Best Practices (Lean Tools and ZED Certification system) on 12th January 2024 at Conference Hall, KINFRA International Apparel Park, Thumba, Thiruvananthapuram. The programme was inaugurated by Shri. Jeevan Anandan, Chief Executive Officer, Kinfra International Apparel Park. The inaugural programme was presided by Shri. Pius Varughese, President, Kinfra Entrepreneurs Association. Shri. A. P. Jose, Former Director, Kerala State Productivity Council & QCI Consultant delivered session on Lean Tools. MSME Competitive LEAN Scheme was explained by Smt. Rekha. K, Assistant Director, MSME DFO, Thrissur. MSME Sustainable ZED Scheme was explained by Shri. Sriram Athimoolam, Deputy Director, Kerala State Productivity Council. The programme was concluded by Q & A session. 56 participants from the industrial park attended the programme. 18 MSMEs registered under MSME Competitive Lean Scheme received LEAN PLEDGE Certificate.



5.3.1.ii Awareness Programme at Kochi on 25.01.2024

MSME-DFO, Thrissur has organized one awareness programme on Enhancing the Competitiveness of MSMEs by Adopting Lean Techniques & Zero Defect Zero Effect Parameters on 25th January, 2024 at RECCA Club Hall, Kakkanad, Ernakulam in association with Export Promotion Council for EoUs and SEZs, Kerala Region. The programme has been inaugurated by Shri. Anilkumar, Regional Governing Council Member of EPCES. He talked about the importance of quality of products and thus reducing rejection in the markets. The inaugural programme was presided by Smt. Lachithamol U.C., Asst. Director, MSME-DFO, Thrissur. Shri. A. P. Jose, Former Director, Kerala State Productivity Council & QCI Consultant delivered session on Lean Tools. MSME Competitive LEAN Scheme was explained by Smt. Lachithamol U.C., Assistant Director, MSME DFO, Thrissur. MSME Sustainable ZED Scheme was explained by Shri. Sriram Athimoolam, Deputy Director, Kerala State Productivity Council. The programme was concluded by Q&A session. 63 participants including the MSMEs from CSEZ attended the program. 18 MSMEs registered under MSME Competitive Lean Scheme and received LEAN PLEDGE Certificates.



5.3.1.iii Awareness Programme at Mattancherry on 02.02.2024

MSME-DFO, Thrissur in association with Indian Chamber of Commerce and Industries, Kochi organized awareness programme on Best Practices (Lean Tools and ZED Certification system) on 02.02.2024 at Chamberhall, Mattancherry, Kochi. The programme was inaugurated

by Shri Job. V. Job., President, Indian Chamber of Commerce & Industry, Kochi. Shri, Binilal, Director, Kerala State Productivity Council & QCI Consultant delivered session on Lean Tools. MSME Schemes were explained by Smt. Rekha. K, Assistant Director, MSME DFO, Thrissur. MSME Sustainable ZED Scheme & MSME Lean Scheme was explained by Shri. Sriram Athimoolam, Deputy Director, Kerala State Productivity Council. The programme was concluded by Q&A session. 45 participants attended the programme.



5.3.1.iv. Awareness Programme at Thiruvalla on 28.02.2024

MSME-DFO, Thrissur organized an awareness programme on LEAN Tools and ZED certification system on 28.02.2024 at Tilak Hotel, Thiruvalla. The programme was presided over by Shri P.B. Suresh Babu, IEDS, Asstt. Director & Programme Coordinator and inaugurated by Shri Sunil, President, Kerala Plastic Manufacturers Association. Shri Jose, Consultant - Kerala State Productivity Council delivered session on LEAN Tools. Shri Shanawas, Joint Director handled session ZED scheme. Schemes of MSME like MSE-CDP, PMS etc. were explained by Shri P.B. Suresh Babu, IEDS, Asstt. Director, MSME DFO, Thrissur. The programme was concluded by Q&A session. A total of 70 participants attended the programme.



5.3.1.v. Awareness Programme at Thrissur on 28.02.2024

MSME-DFO, Thrissur organized awareness programme on LEAN and ZED Tools and Govt. Of India Certification system on 28.02.2024 at MSME DFO, Thrissur. The programme was inaugurated by Shri. G. S. Prakash, Joint Director & HoO, MSME DFO, Thrissur. Shri. Sriram Athimoolam, Deputy Director, Kerala State Productivity Council & QCI Consultant delivered

session on Lean Tools and MSME sustainable ZED scheme. MSME Schemes were explained by Smt. Lachithamol UC, Assistant Director, MSME DFO, Thrissur. MSME Lean Scheme was explained by Shri. Yadu S. Nair, Industrial Engineer, Kerala State Productivity Council. Shri. Yadu S. Nair, Industrial Engineer, Kerala State Productivity Council. The programme was concluded by Q&A session. 52 MSME Manufacturing / Service units participated in the programme. 18 pledges were taken by the participants and created respective user id and password.



5.3.1.vi. Awareness Programme at Kalamassery on 29.02.2024

MSME-DFO, Thrissur in association with KSSIA State Office organized awareness programme on LEAN and ZED Tools and Govt. of India Certification system on 29.02.2024 at KSSIA Hall, Kalamassery. The programme was inaugurated by Shri. Nizarudheen, State President, KSSIA and presided by Shri. G. S. Prakash, Joint Director & HoO, MSME DFO, Thrissur. Shri. Binilal Director, Kerala State Productivity Council & QCI Consultant delivered session on Lean Tools. Shri. Sriram Athimoolam, Deputy Director, Kerala State Productivity Council & QCI Consultant delivered session on Lean Tools and MSME sustainable ZED scheme. Latest updates on MSME Schemes was explained by Shri .G. S. Prakash, Joint Director & HoO, MSME DFO, Thrissur. The programme was concluded by Q&A session. 50 MSME Manufacturing/Service units participated in the programme.



5.3.1.vii. Awareness Programme at Thrissur on 06.03.2024

MSME-DFO, Thrissur in association with Kerala Plastics Manufacturers Association organized an awareness programme on Lean Techniques, Zero Defect Zero Effect (ZED) Certification on 06.03.2024 at MSME DFO Thrissur. Shri G.S.Prakash, Joint Director & HoO, MSME DFO Thrissur delivered Presidential Address and the Awareness Programme was inaugurated by Smt. Sheeba. S, General Manager, DIC, Thrissur. Shri J Sunil, President, Kerala Plastics Manufacturers Association (KPMA) delivered Keynote Address and Felicitations were delivered by Shri Muhammad Ashraf, General Secretary, KPMA and Shri George Kutty, Programme Coordinator, KPMA. The technical sessions on Cluster Development Scheme CFC in Plastic Waste Recycling was handled by Shri G. S. Prakash, Joint Director & HoO, MSME DFO Thrissur. A brief session on MSME Lean Scheme & ZED Scheme benefits from M/o MSME was handled by Smt. K Rekha, Assistant Director, MSME DFO Thrissur. Detailed Session on Key Lean Principles, Tools, Techniques and Advantages was handled by Shri Vinod Kanoth, Lean Consultant. And finally the Session on MSME ZED Certification Scheme was handled by Shri K.M. Shanavaz, Joint Director, Kerala State Productivity Council. The programme was attended by 160 participants. Group Discussion at the end of the Technical Session chaired by Shri G.S.Prakash, Joint Director & HoO, MSME DFO Thrissur along with the representatives of Kerala Plastics Manufacturers Association.



5.3.1.viii. Awareness Programme at Kannur on 14.03.2024

MSME-DFO, Thrissur in association with North Malabar Chamber of Commerce(NMCC), Kerala State Small Industries Association and District Industries Centre, Kannur organized awareness programme on LEAN and ZED Tools and Govt. Of India Certification system on 14.03.2024 at North Malabar chamber of Commerce (NMCC), Kannur. The programme was inaugurated by Shri.T K Ramesh Kumar, The President,NMCC , Kannur. Shri A S Shiras, GM, DIC, Kannur delivered Key note address. Shri. Martin P. Chacko, Asstt. Director and programme coordinator, MSME DFO, Thrissur presided the function and delivered a session on Schemes of Min. Of MSME and introduction to the Lean and ZED programme. Shri. Jaison S. Valooran, Industrial Consultant, Kochi delivered session on Lean Techniques and Tools and Lean Scheme in the Fore Noon. In the afternoon, he took a session on ZED concept and programme of the Ministry of MSME, GoI. 74 MSME Manufacturing / Service units, officials from DIC and chamber of commerce etc participated in the programme.



Following shows the Lean implementation status during 2023-2024 in the State of Kerala



Number of enterprise groups established in the state of Kerala due to awareness programmes conducted for further implementation of the intermediate stage of the lean certification programme in MSMEs

Table 5.4: Details of GoEs Formed

GOE Name	Nodal Name	No Of Units
GOE/MCLS/NPC/KL-41	LEAN0006916	10
GOE/MCLS/NPC/KL-56	LEAN0007047	8
GOE/MCLS/NPC/KL-64	LEAN0007614	10
GOE/MCLS/QCI/KL-108	LEAN00010072	10
GOE/MCLS/QCI/KL-119	LEAN00010305	9
GOE/MCLS/QCI/KL-29	LEAN0005091	9
GOE/MCLS/QCI/KL-30	LEAN0005058	8
GOE/MCLS/QCI/KL-88	LEAN0008022	9
GOE/MCLS/QCI/KL-89	LEAN00010102	10

5.4. MSME Innovative(for Incubation, IPR, Design and Digital MSME)

The following table shows the brief details of the assistance available under MSME

Innovative Component.

<p>Nature of assistance</p>	<p>Incubation</p> <ul style="list-style-type: none"> Financial Assistance to HI for developing and nurturing the ideas- shall be provided up to maximum of Rs. 15 lakh per idea to HI. Financial assistance for Plant and Machinery to HI up to Rs. 1.00 cr. (max) - shall be provided for procurement and installation of relevant plant and machines including hardware and software etc. in BI for R&D activities and common facilities for incubatees of BI. <p>Design</p> <ul style="list-style-type: none"> Design Project: 75% of the total project cost will be contributed by GoI up to a maximum of Rs. 40 lakh Student Project: 75% of the total project cost will be contributed by GoI up to a maximum of Rs. 2.5 lakh <p>IPR</p> <ul style="list-style-type: none"> A Grant of up to Rs. 1 crore would be provided to an IPFC in milestone-based (three or more) instalments Reimbursement for registration of Patent, Trademark, Geographical Indications (GI), Design: The maximum financial assistance to the eligible applicants under the IPR <p>i. Foreign Patent – Rs. 5.00 lakh</p> <p>ii. Domestic Patent - Rs. 1.00 lakh</p> <p>iii. GI Registration - Rs. 2.00 lakh</p> <p>iv. Design Registration - Rs. 0.15 lakh</p> <p>v. Trademark - Rs. 0.10 lakh</p>
<p>Eligibility/ Applicability:</p>	<ul style="list-style-type: none"> Incubation: MSMEs, Individuals, Students who want to develop their innovative ideas can apply through registered HIs. Design: The beneficiary unit(s) must typically be a registered micro, small or medium enterprises as per the definition in MSMED Act and should have a valid UAM or Udyam Registration. IPR: For Manufacturing MSMEs with UAM/UDYAM Registration.
<p>How to apply?</p>	<p>The eligible applicants may apply at the MIS portal https://innovative.msme.gov.in</p>

5.4.1. Incubation Component

This section shows the details of implementation status of Incubation component in the State of Kerala.

Table 5.5: List of Host Institutes in Kerala

Sl. No	HI Name	District	Email	Contact No.
1.	Sree Narayana Guru College of Engineering and Technology	Kannur	innovation@sngcet.org	04985201987
2.	National Institute of Technology Calicut	Kozhikode	tbi@nitc.ac.in	04952286147
3.	National Institute of Electronics and Information Technology	Kozhikode	dir-calicut@nielit.gov.in	04952287266
4.	ICAR Indian Institute of Spices Research	Kozhikode	iisrbpd2019@gmail.com	04952731410
5.	Lead College of Management	Palakkad	thomas@lead.ac.in	04912553693
6.	Govt. Engineering College, Palakkad	Palakkad	tbi.gecskp@gmail.com	04662260350
7.	Sreepathy Institute of Management And Technology	Palakkad	sebinsunny@simat.ac.in	04662370200
8.	Christ College of Engineering	Thrissur	jestinejthannickal@cce.edu.in	04862248368
9.	IES College of Engineering	Thrissur	mail@iesce.info	04872309966
10.	Government Engineering College Thrissur	Thrissur	ajay@gectcr.ac.in	04872334590
11.	Adi Shankara Institute of Engineering and Technology Kalady	Ernakulam	asietkerala@gmail.com	04842463825
12.	Muthoot Institute of Technology and Science	Ernakulam	principal@mgits.ac.in	04842732100
13.	Kerala University of Fisheries and Ocean Studies	Ernakulam	kufosbic@gmail.com	04842700598
14.	Federal Institute of Science and Technology	Ernakulam	mail@fisat.ac.in	04842725250
15.	Al Ameen College, Edathala, Aluva	Ernakulam	kalariteesha@gmail.com	04842836221
16.	Mar Baselios Christian College of Engineering & Technology	Idukki	incubation@mhive.in	04869233571
17.	Business Innovation and Incubation Centre	Kottayam	biicmgu2016@gmail.com	04812731035

18.	Rubber Research Institute of India, Rubber Board, Ministry of Commerce, Govt. of India	Kottayam	siby@rubberboard.org.in	04812353311
19.	CMS College	Kottayam	drgigigeorge@gmail.com	04812566002
20.	Indian Institute of Information Technology Kottayam	Kottayam	registrar@iiitkottayam.ac.in	04822202100
21.	Mahaguru Institute of Technology	Alappuzha	director@mahagurutech.ac.in	04792331696
22.	St. Thomas College Ranni	Pathanamthitta	jikkujames8055@gmail.com	04735223463
23.	Amrita Vishwa Vidyapeetham	Kollam	krishna@amrita.edu	04762804504
24.	Indian Institute of Information Technology and Management Kerala	Thiruvananthapuram	ceo.makervillage@iiitmk.ac.in	04712784121
25.	Technopark Technology Business Incubator	Thiruvananthapuram	ceo@startupmission.in	04712700270
26.	Kerala University Business Innovation and Incubation Centre - KUBIIC	Thiruvananthapuram	mchangat@gmail.com	04712305321

5.4.1.i. MSME Idea Hackathon 3.0 (Women)

Office of Development Commissioner (MSME), New Delhi up to 10th August 2023 conducted MSME Idea Hackathon 3.0 (Women) under Incubation component of MSME Innovative Scheme. Publicity about Hackathon was disseminated among the Host Institutions and made necessary arrangements and guidance to invite the applications for Hackathon from Women Innovators/ Women owned MSMEs/ Women Students.

Domain Expert Selection Committee (DESC) for evaluation of ideas received under Miscellaneous sector of MSME Idea Hackathon was constituted vide OMNo.:F.N.6(26)/Inc/ConstitutionofDESC-Hackathon3.012023-24Dated:20/11/2023 from the Office of Development Commissioner (MSME), MSME Champion Scheme Division (Incubation). Miscellaneous sector comprises Environment, Forests, Water & Sanitation; Foods, Beverages, FMCG, Consumer Goods; Infrastructure, Construction, Housing; IT, ITES, Electronics, White Goods, Telecommunication; Metals, Engineering, Machinery, Automation and Transportation, Automotive, E Vehicles, Railways, Aviation, UAV and any other sub-sector.

The evaluations of these 623 ideas received under miscellaneous sector were done by following subject matter experts at MSME-DFO, Thrissur from December 11, 2023 to December 15, 2023.

1.	Dr. Mukundan M.K, NRA 4, Narayan Asan Road, Vyttila, Kochi
2.	Dr. T.K. Dhamodaran, Tathamangalath House, Thalore P.O, Thrissur
3.	Dr. K.R. Anilakumar, Kandangath House, Kaiparambu P.O, Thrissur
4.	Shri. Sreekanth Padmarajan, H.No:4, ChaithanyaNagar, Parapuram, Perumbavur



Expert Committee members along with Shri.G.S.Prakash, Joint Director & Head of Office, MSME-DFO, Thrissur after evaluation of 623 ideas under Miscellaneous sector

The expenditure incurred for evaluation of ideas was Rs. 1,48,694/-. The 7th PMAC Meeting of MSME Innovative held was held on 15.02.2024 & the results of Hackathon3.0 was announced by Hon'ble Minister of MSME on the occasion of CPSE Conclave at Vigyan Bhawan, New Delhi on 29.02.2024



Minister of State MSME announcing the results of MSME Idea Hackathon 3.0

Ideas approved from the State of Kerala under MSME-Idea Hackathon 3.0 during the FY 2023-2024 are as given below:

Sl. No	Name of Host Institute	Details of Ideas proposed
1	Lead College of Management, Palakkad	Kerala innovations devices(banana slicer, areca nut de-husker, coconut de-husker)
2	Adi Shankara Institute of Engineering and Technology, Kalady	Smart energy metering system
3	Amrita Vishwa Vidyapeetham	Kerala Fabrication of hybrid electrochemical device using cathodic ni based ldmos 2/mxene nano composites and anodic mos2/mxene





Cumulative details of the ideas supported are as follows:

Table 5.6: Details of Ideas Supported

Sl. No	Name of Host Institute	Details of Idea proposed	Amount Sanctioned (in lakhs)
1	Adi Shankara Institute of Engineering and Technology Kalady	Asegurar Vida (Low cost egg sorting machine for hatcheries)	8.925
2		Smart energy metering system	8.925
3	Rubber Research Institute of India, Rubber Board, Kottayam	Development of eco-friendly Grow-bags based on natural rubber for agri/horticultural activities	8.925
4		Development of Natural Rubber based Insoles and lining materials for artificial limbs	8.925
5	Government Engineering College, Thrissur	Automated coconut harvester with maturity detector	10.50
6		Namaste the No waste App	10.50
7		Intelligent Shopping Trolley	2.975
8		Phoenix - Drone Based Solution for Human-Wildlife Conflict	4.55
9	Govt. Engineering College, Palakkad	Real-time LPG monitoring and automated booking system	10.5
10	Indian Institute of Information Technology Kottayam	Integrated Medical Alert Communication System	8.925
11		Auto Hire - An AI-Based Automated Technical Interview	8.925

		Solution Create a web based solution to conduct virtual technical interviews with the candidates, To evaluate the interview using AI without any human intervention	
12		Life bed - Cost effective replacement for medical beds with added bedsore prevention and patient tilting feature	8.925
13	Indian Institute of Information Technology and Management Kerala	Agro Farming Robot	0.812
14		IoT based blood bag monitoring system	8.925
15		Development of Electric Backrest with Additional Features of Communication	7.242
16		Aluminium Air Battery-Hydrogen Fuel cell Hybrid system for EVs	8.925
17		FM RDS - Disaster Warning Broadcast System	8.925
18	Sreepathy Institute of Management and Technology, Palakkad	IoT based greenhouse hydroponic system using solar	7.70
19	IES College of Engineering, Thrissur	Energy Production Optimization by Block chain based positioning of Solar Panels.	8.925
20	Lead College of Management, Palakkad	Kerala innovations devices (banana slicer, areca nut de-husker, coconut de-husker)	8.925
21	Amrita Vishwa Vidyapeetham	Kerala Fabrication of hybrid electrochemical device using cathodic ni based ldhmos2/mxene nanocomposites and anodic mos2/mxene	8.925
	Total		170.804

Followings are prototypes developed by the Incubates:

	
<p><i>IoT based blood bag monitoring system</i></p>	<p><i>IoT based green house hydroponic system using solar</i></p>
	
<p><i>FMRDS-Disaster Warning Broadcast System</i></p>	

5.4.2. IPR Component

This section shows the status of various activities under the component IPR during the year 2023-24:

Table 5.7: Status of Various Activities under the IPR Component of MSME Innovation Scheme

Component	During the FY 2023- 24	Cumulative As on 31.03.2024
No. of reimbursement cases		
<i>i. Domestic Patent</i>	7 (Rs. 549270)	12
<i>ii. International Patent</i>	-	4
<i>iii. Trade Mark</i>	47 (Rs.406066)	50
IPR awareness programme conducted if any	1	5

N. of beneficiaries from IPR Awareness programme	54	335
Assistance to entrepreneurs through IPFC	100	340
Setting up of IPFC	1	3 (Kerala State Council for Science, Technology and Environment; MSME-DFO, Thrissur & Amrita University-IPFC)

5.4.3. Design Component

Four applications are being received at the level of Implementing Agency (National Institute of Technology, Calicut). Project Appraisal Committee (PAP) is formed for evaluation of the proposals as given below:

- | | | |
|------------------------------------|---|--|
| 1. Prof & Chairman TBI | - | Chair for the committee |
| 2. Secretary/Joint Secretary TBI | - | Sector Expert |
| 3. Faculty expert from NIT Calicut | - | Technical Expert based on the idea/ proposal |
| 4. Design Expert/Consultant | - | Expert from Industry based on the idea/ proposal |
| 5. MSME-DFO | - | Joint Director MSME-DFO/his nominee |
| 6. JR(Finance)or his nominee | - | Financial Expert |
| 7. CEO, TBI-NITC | - | Convener |

Chapter 6

Marketing and Export Promotion

Marketing, a strategic tool for business development, is critical for the growth and survival of MSMEs. For facilitating promotion of MSMEs, Ministry of MSME has taken policy measures and also various Schemes. The major among them are Public Procurement Policy and Procurement and Marketing Support Scheme.

6.1 Public Procurement Policy (PPP)

The Public Procurement Policy for Micro and Small Enterprises (MSME) order 2012 has mandated every Central Ministry/Department/PSU shall set an annual goal for procurement from the MSE sector at the beginning of the year, with the objective of achieving an overall procurement goal of minimum 25 per cent of the total annual purchases from the products or services produced or rendered by MSEs. Out of 25% target of annual procurement 4% is exclusively reserved for MSEs owned by SC/ST and 3% for MSEs owned by Women entrepreneurs. Following are the features of PPP.

- Tender sets free of cost and exemption from payment of earnest money to registered MSEs.
- MSEs quoting price within price band L-1 + 15%, when L1 is from someone other than MSE, shall be allowed to supply at least 25% of tendered value at L-1 subject to lowering of price by MSEs to L-1
- 358 items are reserved for exclusive procurement from MSEs.
- Ministry /Department/CPSUs shall prepare their annual procurement plan to be uploaded on their official website.
- For enhancing participation of MSEs in government procurement, Ministry/Department/CPSUs shall conduct Vendor Development Programmes or Buyer Seller Meets for MSEs especially for SC/ST entrepreneurs.

6.1.1 Latest Changes in PPP

The policy was amended in 2018, 2021 and 2022. The Ministry has invited suggestions on revised list of 469 items reserved for exclusive purchase from MSEs under Public Procurement Policy. Presently 358 items only reserved for exclusive purchase from MSEs.

6.1.2 Efforts to Improve the Performance of MSEs through PPP

MSME-DFO, Thrissur has used various forums for creating awareness about PPP among MSEs.

National Vendor Development Programme (NVDP) was organized at Thrissur on 29th & 30th September 2023 in which 38 PSUs/ Govt. Depts. took part and presented their procurement details and procedure. 214 MSEs participated in the event. A total of 529 number

of representatives of MSE and PSUs participated in the two days programme. 22 stalls were set in and were occupied by the PSUs/ Dept. to exhibiting their product/service requirement for procurement. Side by side, nearly 38 B2B meets were also organized and platform was created for direct interaction between MSE vendors and Public sectors during the programme.

The policy was discussed during almost all the major programmes organized by MSME DFO. MSME DFO, Thrissur organized 150 such programmes during the FY 2023-24 during which the PPP was also discussed as part of public awareness.

6.1.3 Achievements under PPP

As per the details available, procurement from General MSEs units has crossed intended target of 25 % and reached nearly 40%, whereas procurement from SC/ST owned MSEs have reached near to 0.78% only (The target is 4%). Procurement from women owned MSEs has reached only 1.00% (the target is 3%). These are the major challenges to be addressed.

Table 6.1.: National Public Procurement Data as on 5th April 2024

FY	Total CPSEs (No.)	Total Procurement (INR Cr.)	MSEs Procurement (INR Cr.)	Total Benefited (No.)	SC/ST Procurement (INR Cr.)	SC/ST Benefited (No.)	Women Procurement (INR Cr.)	Women Benefited (No.)
2018-19	166	153484	40399	128152	824	4587	232	1410
2019-20	151	131427	39665	157756	692	6340	393	3666
2020-21	156	145904	40807	176685	757	6844	720	4998
2021-22	126	136684	48103	203473	1070	9041	1358	9199
2022-23	82	31557	12787	32499	227	846	319	1144

(Source: Sambandh portal, Ministry of MSME, Govt. of India)

6.1.4 Report Of National Vendor Development Programme-2023, Thrissur

MSME Development and Facilitation Office, Thrissur and Small Industries Development Bank of India(SIDBI), Kochi jointly organized two days Vendor Development Programme (VDP) with the support of State Bank of India, Canara Bank, Union Bank of India & National Small Industries Corporation(NSIC) on 29th & 30th September 2023. This programme has been organized to facilitate smooth implementation of the policy. The programme objective is to find suitable vendors who can supply goods and service requirements of Ministries, Departments and Public Sector Undertakings and also to provide a platform for B2B engagement between MSEs, Large Scale units and Govt. PSUs/Departments.

The programme comprised of following detailed sessions:

- Presentation of goods/service requirements of PSUs (27 Nos.) about opportunities to do business with them, vendor registration procedures and subsequent B2B meetings.

- Role of organization under Ministry of MSME and support for MSMEs from Ministry of MSME.
- Government-e-Marketplace (GeM) which facilitates public sector procurement.
- TRedS platform to address critical financial needs of MSMEs.
- Delayed payment related grievance redressal through MSME Samadhaan portal
- Newly launched initiative of Govt. of India–Open Network for Digital Commerce(ONDC)

The Chief Guest, Shri. Satyaki Rastogi, General Manager, SIDBI, Regional Office, Bangalore inaugurated the programme by lighting the traditional lamp. Shri G.S. Prakash, Joint Director & Head of Office, MSME-DFO, Thrissur presided the function and welcomed the gathering and briefed about the programme and support from Ministry of MSME. Lt. Gen. K.S. Brar, AVSM, GOC, Dakshin Bharat was guest of honour and delivered key note address followed by Shri A. Sivakumar, General Manager (Materials), Cochin Shipyard Ltd , Kochi addressed the gathering as special guest.



Lighting of Lamp by Shri. Satyaki Rastogi, General Manager, SIDBI, Regional Office, Bangalore



Inaugural Address by Shri. Satyaki Rastogi



Shri G.S Prakash, Jt. Director, MSME DFO, Thrissur delivers Presidential address



Keynote Address by Lt. Gen. K.S. Brar, AVSM,GOC, Dakshin Bharat, the Guest of Honour



Address by Shri. Martin P. Chacko, Assistant Director and Programme Coordinator,

MSME-DFO, Thrissur

Felicitation addresses were made by Dr. I. Bhavadasan Namboothiri, President KSSIA, Thrissur and Shri D. Paul Bright Singh, Chief Manager, NSIC –Kochi. The inaugural function ended with Vote of thanks proposed by Shri K.V. Karthikeyan, DGM, SIDBI-Kochi.



The Audience of the NVDP



Chief Guest of NVDP, Shri. Satyaki Rastogi, General Manager, Regional Office, SIDBI Bangalore Inaugurating the Exhibition of PSUs/Depts.



Visitors to the PSU exhibition stalls of the NVDP

Followed by the inauguration of the programme and exhibition, a series of presentations were conducted by PSUs on their vendor development process and by Depts. on Govt. procurement policy related topics. 13 sessions on 1st day (29th September 2023) and 21 sessions on 2nd day (30th September 2023) were conducted on time as per schedule. Immediately after every session by the PSUs/ Dept., respective B2B sessions were organised in separate hall and B2B reports were collected from the PSUs/ Dept. on conclusion of the B2B meet. Such a way 34 PSUs/Depts. took part in the programme by presenting their goods/service requirement/policy support and vendor registration process. There was participation from 4 state PSUs as well in the programme. Thus total no. of participating PSUs/ Dept. was 38. The following table shows the details of the CPSUs/Govt. Depts. participated in the programmes.

Table 6.3: Organizations Participated in the NVDP

1	MSME- Development & Facilitation Office, Thrissur
2	Government E Market Place (GeM)
3	Bridge Bharat Council
4	Indian Navy

5	Indian Air Force
6	Bharat Petroleum Corporation Ltd(BPCL)
7	Indian Oil Corporation Ltd (IOCL)
8	Cochin Shipyard Ltd
9	Bharat Earth Movers Ltd(BEML), Palakkad
10	Cochin Port Authority
11	Food Corporation Of India
12	Keltron Component Complex Ltd
13	VSSC/ISRO
14	Kerala Agro Machinery Corporation Ltd(KAMCO)
15	FACT
16	Kerala Start Up Mission
17	Open Network For Digital Commerce(ONDC)
18	Mynd Solutions Pvt Ltd, Mumbai (TReDS)
19	Hindustan Organic Chemical Ltd (HOCL)
20	The Alleppey Co-Operative Spinning Mills Ltd
21	IRCTC
22	Small Industries Development Bank Of India (SIDBI),Kochi
23	State Bank Of India (SBI),Thrissur
24	Canara Bank, Thrissur
25	Union Bank Of India ,Thrissur
26	Credit Guarantee Fund Trust for MSE(CGTMSE)

27	DST-Tec- Amrita Viswa Vidya Peetham
28	ITI, Palakkad
29	National Small Industries Corporation(NSIC) Ltd, Kochi
30	MSME- Testing Centre, Chennai
31	MSME –Technology Centre- Kochi
32	GAIL
33	Southern Railway
34	Integrated Coach Factory(ICF), Chennai

Around 528 stakeholders participated in the programme in which 214 were MSEs. The programme concluded successfully on 30.09.2023.

6.1.5 Visit of Department Related Parliamentary Standing Committee to Kochi

The Department Related Parliamentary Standing Committee visited Kochi on 27.01.2024 at Kochi. During the public procurement policy related meeting with CPSUs, CMD of Cochin shipyard, BPCL & FACT appreciated the efforts of MSME-DFO in vendor development. CMD Cochin shipyard, in his slide, included the details of the VDP conducted by MSME DFO, Thrissur in association with shipyard and appreciated DFO, Thrissur.

As per the directions from the Chairman DRPSC, associations were invited for the meeting along with 14 office bearers from various associations including KSSIA, LUB, Assocham, Chamber of Commerce, Cochin Export Zone Industries Association, All India Food Processing Industries association, Plastic Manufacturers Association, Traders Association etc attended the meeting. They raised many issues & suggestions and submitted representations to the DRPSC committee.



Members of DRPSC interacting with the representatives of MSME Associations

6.2 Micro and Small Enterprise Facilitation Council (MSEFC), Kerala

The Micro, Small and Medium Enterprise Development (MSMED) Act, 2006 contains provisions of Delayed Payment to Micro and Small Enterprise (MSEs). (Section 15 - 24). Accordingly State Governments established Micro and Small Enterprise Facilitation Council (MSEFC) for settlement of disputes on getting references/filing on Delayed payments (Section 20 and 21). MSEFC of the State after examining the case filed by MSE unit will issue directions to the buyer unit for payment of due amount along with interest as per the provisions under the MSMED Act 2006. Any Micro or small enterprise having valid EM Part -II/UAM can apply.

The provisions under the Act are implemented by MSEFC chaired by Director of Industries of the State/UT having administrative control of the MSE units. State Government/UTs are requested to ensure that the MSE Facilitation Council hold meetings regularly and delayed payment cases are decided by the Councils within a period of 90 days as stipulated in the MSMED Act, 2006.

6.2.1 MSEFC in Kerala

In exercise of the powers conferred by Section 20 of the MSMED Act, 2006, the Government of Kerala has established three Regional Micro and small Enterprises Facilitation Councils at District Industries Centres, Thiruvananthapuram, Ernakulam and Kozhikode, in addition to the State Micro and Small Enterprises Facilitation Council at Directorate of Industries & Commerce, Thiruvananthapuram. The details of current status of MSEFCs in the State of Kerala are as follows:

6.2.1.i State MSEFC , Thiruvananthapuram

- Deals with dispute value of rupees one crore and above
- Address:- Director of Industries & Commerce, Government of Kerala, Vikas Bhavan P.O, Thiruvananthapuram, Kerala- 695033, Phone No:-0471- 2302774

Three Regional MSEFCs

- Deals dispute value below rupees One Crore
- **MSEFC Kozhikode**- District Industries Centre, Vellayil, Kozhikode, 673011;
Phone No: - 276577
Jurisdiction: Kasaragod, Kannur, Kozhikode and Wayanad Districts
- **MSEFC Ernakulam**- Address:- District Industries Centre, Kakkanad, Ernakulam, 682030;
Phone No: - 2421461
Jurisdiction: Palakkad, Thrissur, Ernakulam, Idukki, Kottayam Districts
- **MSEFC Thiruvananthapuram**- Address:- Regional MSEFC, Thiruvananthapuram, District Industries Centre, Water Works Compound, Vellayambalam, Thiruvananthapuram - 695 033, Phone 91-471-2326756, Email Id:- tvmdic@gmail.com
Jurisdiction: Thiruvananthapuram, Kollam, Pathanamthitta and Alappuzha Districts

6.2.2 MSME SAMADHAAN Portal Service–An Initiative by Office of DC (MSME), M/o MSME

Office of DC-MSME has taken an initiative for filing online application by the supplier MSE unit against the buyer of goods/services before the concerned MSEFC of his/her State/UT. At present, the applicant MSE unit submits an application in writing to the MSEFC of his/her State/UT. Using the services of MSME Samadhaan Portal, the supplier MSE unit can submit online application which will be viewed by the concerned MSEFC for further necessary action as per provisions of MSME Act, 2006.

**Table 6.4: MSME SAMADHAAN – Delayed Payment Monitoring Portal – MSEFC Council
Wise Pendency Report <https://samadhaan.msme.gov.in> Date of Report: - 04/04/2024**

S.No.	MSEFC Council	Applications filed by MSEs	Applications Disposed by MSEFC Council	Action Taken by MSEFC Council **	Pending as Now ***	Pending 0 to 15 days	Pending 16 to 30 days	Pending 31 to 60 days	Pending 61 to 90 days	Pending 91 to 180 days	Pending 181 to 365 days	Pending more than 1 year
		Amount Payable as per applications Filed (Rs. Crore)	Amount Payable in Disposed Application (Rs. Crore)/ Amount Settled By MSEFC Council (Rs. Crore)	Amount Payable in Action Taken by MSEFC Council Applications (Rs. Crore)	Amount Payable in Pending as Now (Rs. Crore)	Amount Payable in Pending 0 to 15 days (Rs. Crore)	Amount Payable in Pending 16 to 30 days (Rs. Crore)	Amount Payable in Pending 31 to 60 days (Rs. Crore)	Amount Payable in Pending 61 to 90 days (Rs. Crore)	Amount Payable in Pending 91 to 180 days (Rs. Crore)	Amount Payable in Pending 181 to 365 days (Rs. Crore)	Amount Payable in Pending more than 1 year (Rs. Crore)
1	MSEFC Ernakulam	1072	169	642	261	16	8	28	11	70	76	52
		115.17	22.41	65.92	26.84	6.11	0.43	1.27	0.68	2.48	6.6	9.26
			15.42									
2	MSEFC Kozhikode	415	37	258	120	7	3	26	6	37	23	18
		24.83	5.57	11.76	7.5	0.08	0.2	0.64	0.09	4.2	1.59	0.7
			1.54									
3	MSEFC Thiruvananthapuram	357	87	209	61	3	14	5	8	4	14	13
		40.07	8.41	13.42	18.24	7.42	1.7	1.29	0.5	5.85	0.75	0.74
			2.71									
4	MSEFC Kerala	50	24	23	3	0	1	1	0	1	0	0
		209.14	126.83	77.93	4.38	0	1.18	1.3	0	1.9	0	0
			72.67									
Total		1894	317	1132	445	26	26	60	25	112	113	83
		389.21	163.22	169.03	56.96	13.61	3.51	4.5	1.27	14.43	8.94	10.7
			92.34									

** Applications Rejected by MSEFC Council + Mutually Settled Applications + Applications Converted into Case by MSEFC Council Under various stages of hearing

*** Applications ready for Consideration by MSEFC Council + Applications to be made actionable by council

6.3 Government e Marketplace (GeM)

MSME-DFO, Thrissur has taken various efforts to onboard MSMEs to the MSMEs. Two exclusive awareness programmes were organised on Government e Marketplace (GeM) during 2023-24 financial year in association with the GeM authority, New Delhi. One at Kalamasery, Kochi and second at MSME-DFO Office, Thrissur. 152 MSE units participated in the awareness programme. The sessions were taken by the Dy. CEO of GeM office at New Delhi and state GeM facilitator.

MSME-DFO, Thrissur organized nearly 150 different outreach programmes across Kerala during FY 2023-24. During the above programmes, an awareness session on GeM was included. As such many MSMEs were made aware of benefits of registering in GeM portal for supply of goods and services to Govt.

Table 6.5: GeM Procurement from the SME Sector of Kerala

Financial Year	Procurement from MSEs in Kerala			Procurement from SC/ST MSEs in Kerala			Procurement from Women MSEs in Kerala		
	Value (in INR Lakh)	Share of procurement from Kerala MSEs as a %age of the total Procurement from MSEs on GeM	MSEs Benefitted (No. of MSEs)	Value (in INR Lakh)	Share of procurement from Kerala SC/ST MSEs as a %age of the total Procurement from SC/ST MSEs on GeM	MSEs Benefitted (No. of MSEs)	Value (in INR Lakh)	Share of procurement from Kerala Women MSEs as a %age of the total Procurement from Women MSEs on GeM	MSEs Benefitted (No. of MSEs)
2021-22	64,907.83	1.11%	737	37.06	0.04%	7	3,553.09	0.76%	32
2022-23	1,11,257.28	1.15%	1,159	101.42	0.09%	6	3,908.97	0.61%	46
2023-24	2,18,381.02	1.17%	1,634	392.55	0.32%	5	5,499.01	0.76%	42

Table 6.6: GeM Procurement by Kerala Based PSUs/ Govt. Departments

Financial Year	Value of Procurement by Kerala based PSUs / Govt. Dept. (in INR Lakhs)
2021-22	38,845.38
2022-23	46,612.09
2023-24	54,315.17

The following shows the all India status of GeM

149,392 Primary Buyers	216,705 Secondary Buyers	12,080 Product Categories
322 Service Categories	6,279,403 Order Volume in Last FY	403,707 Order Value in Last FY (Cr.)
14,375 Order Volume in Current FY	2,002 Order Value in Current FY (Cr.)	49.24 Orders Value (MSE %)

6.4 Procurement and Marketing Support Scheme

Due to the lack of information, scarcity of resources and unorganized ways of selling/marketing, MSME sector often faces problems in exploring new markets and retaining the existing ones. Keeping in view these facts, the Procurement and Marketing support Scheme has been introduced to enhance the marketability of products and services in the MSME sector. The Scheme aims at improving the marketing competitiveness of MSME sector by promoting new market access initiatives like organising trade fairs and by creating awareness to improve marketing techniques and technology in packaging, etc.

The key benefits under the scheme which can be availed by the existing entrepreneurs are as follows:

- Reimbursement of a maximum of Rs.1.5 Lakhs for Metro & A class cities, a maximum of Rs 1.0 lakhs for Class B cities/NER/J&K/Hilly States and a maximum of Rs.0.80 lakhs for other cities for MSEs to participate in domestic trade fairs/exhibitions across the country which are approved by the Office of Development Commissioner (MSME), New Delhi. The list of approved events are available on the website and interested MSEs can apply for benefit prior to the Trade Fair: https://my.msme.gov.in/MyMsme/Reg/COM_ViewEvent.aspx
- Financial support for organizing Domestic Trade Fairs/Exhibition and participation in trade fairs/exhibitions by the Ministry/Office of DC (MSME)/Government organizations, both physical and virtual programmes.
- Sanction of a maximum of Rs 5.0 lakh/program or actual, whichever is less, per program to organise Vendor Development Programmes
- Sanction of a maximum of Rs 15 lakh/cluster or actual, whichever is less, depending upon the nature of the approved Cluster, for the Cluster based interventions for specific packaging and branding requirements.
- Providing financial assistance of 80% of one-time registration fee and annual recurring fee (for first three years) paid by micro enterprises for obtaining up to 1000 Nos. of bar codes (i.e. products) or actual whichever is less subject to Rs. 50,650/- max. The Micro Enterprises can apply for benefits through the link https://my.msme.gov.in/MyMsme/Reg/COM_MatuBarAppForm.aspx
- A maximum of Rs. 5.0 lakh or actual, whichever is less per workshop/seminar to organize National workshops / Seminars to educate MSMEs on various facets of business development i.e. product & process development innovations, technological development, EXIM policy, Public Procurement Policy, adoption of e- commerce, design & packaging, market research and access.

The following sections show the status of implementation of various activities under Procurement and Marketing Support Scheme.

6.4.1 Reimbursement for Participating in Domestic Trade Fairs – Component 5 I (A) of PMS Scheme

During the FY Rs. 101.812 lakhs have been reimbursed to the MSEs participated in the Industrial Exhibitions across the country. Details are as follows:

Table 6.7: Status of Reimbursement under 5I(A) Component of PMS Scheme

Sl No	Name of the Trade Fair / Exhibition / Event	Amount Utilized / Expenditure booked during FY 2023-24 (INR Lakh)	No of MSEs Availed the Benefit
1	Agro Food Pro 2022-23, Thekkinkadu Maidan, Thrissur (04.02.2023 to 07.02.2023)	9.618	54
2	5th Machinery Expo 2022-23, Kaloor International Stadium, Ernakulam (11.03.2023 to 14.03.2023)	14.37	41
3	Global Assistive Technology Expo & Conference (GATEC) 2022, Greater Noida (23.03.2023 to 25.03.2023)	1.6	2
4	IAAPI Amusement Expo, Hall 2, Bombay Exhibition Center, Mumbai (01.03.2023 to 03.03.2023)	1.5	1
5	IndExpo Nagpur (16.02.2023 to 18.02.2023)	0.8	1
6	35th Industrial India Trade Fair, Kolkata (23.12.2022 to 01.01.2023)	0.504	1
7	Print Miracle Expo 2023 at Kochi (20.01.2023 to 21.01.2023)	3.82	8
8	HGH India Mumbai (13.02.2022 to 18.12.2022)	1.57	1
9	Truck and Trailer Tyre Expo, Comibatore (16.12.2022 to 18.12.2022)	0.8	1
10	Odisha Buildcon, Bhubaneswar (22.12.2022 to 24.12.2022)	0.59	1
11	Fifex 2023 (FuMMA International Furniture Exhibition 2022), Angamaly (06.05.2023 to 08.05.2023)	45.03	58
12	Autosec 2023, Ernakulam (26.05.2023 to 27.05.2023)	11.31	20

13	Agri Intex 2023, Coimbatore (14.07.2023 tp 17.07.2023)	0.76	1
14	HGH India Mumbai (04.07.2023 to 07.07.2023)	1.35	1
15	14th Toy Biz International B2B Exhibition, New Delhi (08.07.2023 to 11.07.2023)	0.82	1
16	Tag Expo 2023, Erode, TN (24.07.2023 TO 26.07.2023)	1.15	2
17	13th Stainless Steel Houseware Show 2023, Mumbai (18.08.2023 to 20.08.2023)	0.76	1
18	Automation Expo South 2023, Chennai (26.04.2023 to 28.04.2023)	1.05	1
19	Comexpo, Chennai (09.06.2023 to 11.06.2023)	0.85	1
20	6th Health and Wellness Expo 2023, New Delhi (02.06.2023 to 04.06.2023)	1.06	1
21	International Plastics Exhibition, Chennai (10.06.2022 to 13.06.2022)	0.93	1
22	International Dairy Expo and Food Expo, Hyderabad (03.02.2023 to 05.02.2023)	0.93	1
23	Print & Packtech World Expo 2023, Bangalore (26.05.2023 to 29.05.2023)	0.64	1
Total		101.812	201

6.4.2 Participation in IITF 2023 under 5 I (B) Component of PMS Scheme

MSME-DFO, Thrissur could mobilize 70 applications for IITF 2023 and made necessary recommendations as per the score card. 4 MSEs from Kerala were selected by the Empowered Committee at O/o DC(MSME)MSEs in the 41st India International Trade (IITF 2023) from 14 - 27 November 2023 at Pragati Maidan, New Delhi, through the MSME Pavilion of O/o DC (MSME), New Delhi. The selected MSEs were provided with all the assistance required to materialize their participation and they managed to get inquiries about their products at the National and International Levels.

6.4.2.i Adoption of Barcode- Reimbursement under 5 II (B) Component of PMS Scheme

Under the Scheme Component, Ministry of MSME is providing financial assistance of 80% of one-time registration fee and annual recurring fee (for first three years) paid by micro enterprises for obtaining up to 1000 Nos. of bar codes (i.e. products) or actual whichever is less subject to Rs. 50,650/- max. The eligible Micro Enterprises with Udyam Registration can apply for the reimbursement through the web link after obtaining GS1 Barcode.: https://my.msme.gov.in/MyMsme/Reg/COM_MatuBarAppForm.aspx

During the FY 2023-24, MSME-DFO, Thrissur has reimbursed Rs. 5.98 lakhs to 14 Micro Enterprises from Kerala for obtaining Barcode.

6.4.2.ii National Workshops under 5 II (C) Component of PMS Scheme

During the year 2023-24, MSME-DFO, Thrissur has been allotted with 4 National Workshops under 5 II (C) Component of the PMS Scheme. The details of the programmes are shown in the following table:

Table 6.8: National Workshops under PMS Scheme

Sl No	Programme Type	Topic and Place	Date	Total Number of Participants	Fund Sanctioned (Rs.)	Expenditure Incurred (Rs.)
1	National Workshops under PMS Scheme	National Workshop on Export Marketing for Food Processing Industries at Kochi	11.10.2023	324	5,00,000	4,99,708
2		National Workshop on Export Promotion and Marketing at Thiruvananthapuram	02.12.2023	265	5,00,000	4,99,490
3		National Workshop on Export Promotion, Marketing and Value addition at Changanassery	12.01.2024	300	5,00,000	5,00,000

4		National Workshop on Export and Marketing for MSMEs at Kozhikode	01.03.2024	275	5,00,000	4,89,500
Total				1164	20,00,000	19,88,698

MSMEs are often called the powerhouse of the Indian economy. MSMEs contribute significantly to employment generation, exports, and overall economic growth. They reportedly account for more than 11 crore jobs and contribute around 27.0% of India's GDP. According to estimates, the sector consists of around 6.4 crore MSMEs, with 1.5 crore of them registered on the Udyam portal and employs around 23.0% of the Indian labour force, making it the second-largest employer in India after agriculture. They account for 38.4% of the total manufacturing output and contribute 45.03% of the country's total exports. Exports represent an enormous and under-utilized opportunity for the MSME sector. Sectors where Indian MSMEs can participate and compete in export markets include handicrafts, handloom textiles, ayurveda and herbal supplements, leather goods, imitation jewellery and wooden products. Globally, these sectors constitute substantial markets exceeding USD 340 billion, whereas their domestic market is considerably smaller.

On this background, MSME-Development and Facilitation Office, Thrissur has organized 4 National Workshops on the topic 'Export Marketing' with the following objectives:

- *to create awareness about opportunities in the Export Market*
- *to discuss about strategies to utilize the opportunities and global product innovative trends, etc*
- *to create awareness about the support from various Government Departments to promote Export*
- *To facilitate to tap further potential of MSME sector in the State and to create platform to interact, update and prepare a way forward.*

Brief details of the National Workshops are as follows:

a. National Workshop on "Export Marketing for Food Processing Industries" at Hotel Abad Plaza, Kochi on 11.10.2023

MSME-Development and Facilitation Office Thrissur organized one National Workshop on Export Marketing for Food Processing Industries at Kochi on 11th October, 2023 to equip MSMEs with knowledge to enhance their capabilities and explore new avenues. The programmes have been organized in association with Baker's Association, Kerala. The Workshop has been envisaged as a one day event with sessions on Emerging Opportunities in Export Market and Documentation Procedures, Supports from Government Organisations,

especially the Export Promotion Councils, Emerging Opportunities through Government E-Commerce Platforms, Support for MSMEs from Various Government Organisations and Export Finance from Financial Institutions, Experience sharing by prominent Exporter in the State and also various Help Desks of Government Departments and Financial Institutions. Smt. Lachithamol U.C., Asst. Director, MSME-DFO, Thrissur delivered the welcome address and the program schedule. Shri. G.S. Prakash IEDS, Joint Director and Head of Office presided over the function. Shri.V.R.Vinod IAS, Commissioner of Food Safety, Office of the Commissioner of Food safety, Government of Kerala inaugurated the program virtually. He cited the importance of the Food Processing Sector. He has appreciated the initiatives being taken by MSME-DFO, Thrissur for strengthening the MSME ecosystem of the State. Shri. Sai Krishna Prasad, Deputy Director General of Foreign Trade, Office of JDGFT, Kochi; Dr. Mukundan, Former Director of CFRD, Konni; Shri. Abraham Thomas Puthoor, Head of Business, Rise Bakery, Dubai were Guests of Honours. Shri Kiran S Palakkal, State President, Bakers Association Kerala (BAKE) delivered special address. Shri. Naveen, State Secretary, Bakers Association Kerala proposed vote of thanks during the inaugural function.



Presidential Address by Shri. G.S.Prakash IEDS, Joint Director & HoO



Address by Guest of Honor, Shri. Sai Krishna Prasad, Deputy Director General of Foreign Trade



Address by Smt. Lachithamol U.C., Asst. Director and Programme Coordinator, MSME-DFO, Thrissur

The programme had 5 theme-based Sessions. In these, selected themes were discussed in which eminent speakers shared their knowledge. At the end of each session, there was an open forum with Q&A. The details of the technical sessions and speakers are as shown below:

- i. The introductory session on Exploring Global Bakery Market - Opportunities & Challenges have been handled by Shri. Abraham Thomas Puthoor, Head of Business Rise Bakery, Dubai who explained about the strategies to be followed to tap the opportunities, especially regarding product differentiation, pricing decisions and efforts should be taken to identify the buyers.

- ii. The second technical session on the topic *“Emerging Opportunities on Export Market”* followed by Q&A and discussions on the following areas:
 - a. Effective Strategies of Marketing for MSMEs- Emerging Scenario-Introduction- Prof Cherian Peter, Professor, SCMS Cochin School of Business, Kalamassery
 - b. Analyzing the Export Potential of the Enterprise and Identifying Buyers in International Business-Dr. Reji Kumar G., Senior Professor, Amrita School of Business, Kochi
 - c. Scope for MSMEs in the International Market and Documentation Procedures - Shri K J Bonniface, Export Business Consultant
 - d. ZED Certification, LEAN Manufacturing and Marketing Supporting Schemes in the Context of International Business – Shri. G.S.Prakash, Joint Director and HoO of MSME-DFO, Thrissur and Shri. Shanavaz, Joint Director of Kerala State Productivity Council.

- iii. The following sessions were taken in the afternoon technical session on *“Emerging Opportunities for MSMEs in the Global Market and Supports from Government Organizations”*:
 - a. Support and services from FIEO- Shri Rajeev MC, Head, FIEO, Kerala Chapter
 - b. Support and services from APEDA – Smt. Maneesha S., Business Development Manager, APEDA
 - c. Covering the Risk in International Business: Role of ECGC- Smt. Meghna Edakalathur, Asst. Manager, ECGC, Kochi
 - d. Support and services from NSIC -Smt Grace Reji, Manager, NSIC, Kochi

- iv. The final technical session was on *“Emerging Opportunities through Government E Commerce Platforms”*. The sessions were as follows:
 - a.** Open Network for Digital Commerce (ONDC) - Shri. Rahul Radhakrishnan, State Manager, Kerala
 - b.** Government E-market Place- Shri. Manesh Mohan, State Business Facilitator, GeM



From Technical Sessions

As a part of the National Workshop, MSME-DFO, Thrissur has arranged various help desks for the benefit of the participants. The programme concluded with Valedictory Session. Shri. G.S.Prakash, IEDS, Joint Director & HOO of MSME-DFO, Thrissur gave a brief about the proceedings of the day. Shri. K.K. Pillai, Authority Member, APEDA & Officiating Regional Chairman, EPC for EOUs & SEZs, Government of India; Member of Export Promotion Council, Under Ministry Of Commerce, delivered the valedictory address. Shri. Karthikeyan, DGM, SIDBI, Smt. Namitha, ADIO, District Industries Centre, Ernakulam and Shri. Anoop, Regional Manager of Treasury, SBI, Shri. Naveen, Secretary of Bakers Association, Kerala were addressed the participants during the summing up. Participants shared their feedback about the Programme.



Valedictory address by Shri. K.K. Pillai, Authority Member, APEDA



Help desks

324 participants including existing entrepreneurs from the food processing sector, Govt. officials and other stakeholders attended the workshop and the programme had a virtual streaming through the Official YouTube Channel as well.



View of Participants

b. National Workshop on Export Promotion and Marketing on 02nd December 2023 at Hotel Apollo Dimora, Thiruvananthapuram

Ministry of Micro, Small & Medium Enterprises, Government of India, MSME-Development & Facilitation Office, Thrissur and Small Industries Development Bank of India, Thiruvananthapuram jointly organized National Workshop on Export Promotion and Marketing on 02nd December 2023 at Hotel Apollo Dimora, Thiruvananthapuram. The objective of the programme was to create awareness about the opportunities in the Export Market, the strategies to utilize the opportunities, global product innovative trends, etc among the MSMEs in order to use competitive global market and to create more exports. The programme was inaugurated by Shri. C.Padmakumar, Special Officer, Kerala Medical Technology Consortium and Director, Kerala Life Sciences Parks Private Limited and Director, Padosan Trading Private Limited. In his address he explained about his journey while he was Chairman & Managing Director of Terumo Penpol Private Limited and stressed participants to utilize the ample opportunities and incentives offered by Central and State Government to boost MSME exporters. Shri. G.S.Prakash, Joint Director & Head of Office, MSME-DFO, Thrissur presided over the function and explained in detail about the Programmes and Policies offered by Ministry of MSME, E-Commerce Exports in collaboration with Ministry of MSMEs and Procedures Export-Import. Shri.P.R.Savishesh, Deputy General Manager, Small Industries Development Bank of India, Thiruvananthapuram explained in brief about schemes of SIDBI during special address. Shri.K.J.Stephen, Section Head, DGFT and Shri.Pradeep Kumar C.S, President, KSSIA, Thiruvananthapuram addressed during the inaugural session.



Presidential Address by Shri. G.S.Prakash, Joint Director and HoO, MSME-DFO, Thrissur



Inaugural Address by Shri. C.Padmakumar, Special Officer, Kerala Medical Technology Consortium



Address by Smt. Rekha K., Asst. Director and Programme Coordinator, MSME-DFO, Thrissur

The programme had 9 eminent speakers. At the end of each session, there was an open forum with Q & A. The details of the technical sessions and speakers are as shown below:

- i. Session on Logistics and Export Market (International business, Sea Cargo and Air cargo, Clearing & Forwarding Shipping, Freight forwarding and Console, Warehousing, Packing & Marking, Transporting, Other allied and incidental services involved in business Logistics, Explore export market, procedure execution, export promotion organizations, services offered by DGFT)- was handled by Shri. K.J. Bonniface, M/s.CKR Group of Companies, Kochi
- ii. The Role of DGFT in Promotion of Export Business-Shri. T.V. Stephen, Section Head, DGFT
- iii. Role of National Small Industries Corporation for Export Promotion in MSMEs - Shri. D Paul Bright Singh, Chief Manager, National Small Industries Corporation, Cochin
- iv. Digital Marketing - Shri. Ajay S Nair, Founder & CEO, Fresh Mind Ideas
- v. Open Network for Digital Commerce - Shri. Rahul Radhakrishnan, Open Network for Digital Commerce (ONDC), State Manager- Kerala
- vi. Programmes and Policies of M/o MSME- Shri. G.S.Prakash, Joint Director & Head of Office, MSME-DFO, Thrissur
- vii. DAK Nirayat Kendra-Shri. Praveen S, Marketing Executive, Thiruvananthapuram GPO
- viii. Financial Support for Export for SIDBI- Shri. Geo Pious, Manager, SIDBI, Thiruvananthapuram
- ix. Government E Marketplace-Shri. Manesh Mohan, Business Facilitator, Government E Marketplace (GeM)



From Technical Sessions

The programme was attended by 265 participants from individual MSMEs, members of various associations like Kerala State Small Industries Association, Thiruvananthapuram Chamber of Commerce, Confederation of Indian Industry, Laghu Udyog Bharathi, product specific associations etc. The programme concluded by 06.45 PM and the feedback received was good.



View of Participants

c. National Workshop on Export Promotion, Marketing and Value addition at Contour Backwaters Changanassery on 12.01.2024

MSME Development and Facilitation Office, Thrissur under the Ministry of MSME, Government of India in association with DI&C, GoK, KSSIA, LUB Central Travancore Chamber of commerce and Industry, SIDBI, NSIC, NABCON, and Department of Post, GoI organized one day National workshop on “Export Promotion, Marketing and Value Addition” on 12.01.2024 at Contour Back Waters, AC Road, Changanacherry, Kottayam. The programme has been inaugurated by Smt. P. Hemalatha, IAS, Development Commissioner - Cochin Special Economic Zone, Cochin. Shri. G.S. Prakash, Joint Director & Head of Office of MSME DFO, Thrissur presided over the inaugural function. Shri P.B. Suresh Babu, IEDS, Asstt. Director & Programme Co-ordinator welcomed the gathering and Shri Vishesh Aggarwal, A.D. (Stat.) proposed vote of thanks during the inaugural function.



Presidential Address by Shri. G.S.Prakash, Joint Director and HoO, MSME-DFO, Thrissur



Formal Inauguration of National Workshop by Lighting the lamp by Smt. P. Hemalatha, IAS, Development Commissioner - Cochin Special Economic Zone



Address by Shri. P.B. Sureshbabu, Asst. Director and Programme Coordinator, MSME-DFO, Thrissur

The National Workshop had following technical sessions:

- i. Logistics & Export Market – (International Business, Sea Cargo and Air Cargo, Clearing & Forwarding Shipping, Freight forwarding and Console etc.) by Shri. K.J. Bonniface, CKR Group of Companies, Kochi.
- ii. Export Promotion – Services offered by Federation of Indian Export Organizations by Shri. Rajeev M.C., Kerala Head, Kerala Chapter – Federation of Indian Export Organizations, Kochi.
- iii. “Export Promotion” by Shri. Stephen T.V. Section Head DGFT, RA, Kochi.

- iv. MSME Ministry's Schemes for Market, Export & Adopt best practices by Shri. G.S. Prakash, Joint Director & HoO of MSME - DFO, Thrissur
- v. Value addition methods in Food Processing and Food Safety” by Dr. M.K. Mukundan, Managing Faculty – MIFT (Former Director CFRD)
- vi. “Open Network for Digital Commerce” by Shri Rahul Radhakrishnan, Open Network for Digital Commerce (ONDC) State Manager – Kerala
- vii. Government e-Marketplace by Smt. Reena Sasikumar, GeM Facilitator – TCS
- viii. DAK – Nirayat Kendra by Shri Induchoodan P.R. Marketing Executive, Kochi H.O.
- ix. Financial Schemes offered by SIDBI for MSMEs by Ms. Alina George, Asstt. Manager, SIDBI.
- x. Role of National Small Industries Corporation for Export Promotion in MSMEs by Shri Jeo John Chalakkal, Manager, National Small Industries Corporation (NSIC), Branch Office, Thrissur.
- xi. Interest Subversion Scheme – Agri Infrastructure Fund Eligibility/ Eligible Activity by Zonal Coordinator, Agri Infrastructure Fund NABARD Consultancy (NABCONS) handled by Smt. Aswathy Mohan Zonal Coordinator



From Technical Sessions

As a part of the National Workshop, MSME DFO, Thrissur has arranged various help desks for the benefit of the participants. The programme concluded with Vaedictory Session in which participants shared their feedback about the Programme. Around 300 participants

including existing entrepreneurs from the food processing sector, Govt. officials and other stakeholders attended the workshop and the programme had a virtual streaming through the Official YouTube Channel as well.



View of Participants

d. National Workshop on Export and Marketing for MSMEs at Hotel Manuelsons Malabar Palace, Kozhikode on 01.03.2024

MSME-DFO, Thrissur has organized a one day National Workshop on “Export and Marketing for MSMEs” on 01st March 2024 at Manuelsons Malabar Palace, Kozhikode. The objective of the programme was to create awareness about the opportunities in the Export Market, the strategies to utilize the opportunities, global product innovative trends, etc among the MSMEs in order to use competitive global market and to create more exports. Smt. Lachithamol U.C., Asst. Director, MSME-DFO, Thrissur delivered the welcome address and the program schedule. Shri. G.S. Prakash, Joint Director and Head of Office has presided over the function. Shri. VKC Razak, Managing Director of VKC Group inaugurated the program. Being one of the major footwear manufacturers in the country, he motivated the MSMEs about the need to be sustainable in the business and urged them to utilize the opportunities available in the global market. He has appreciated the initiatives being taken by MSME-DFO, Thrissur for strengthening the MSME ecosystem of the State. Shri. Renjith Babu, General Manager, District Industries Centre, Kozhikode; Shri. K.A. Vijayan Menon, State Level Convener, Engineering Export Promotion Council and Laghu Udyog Bharati; Shri. Babu Maliyekkal, Secretary, KSSIA, Kozhikode were Guests of Honours. Shri. Vishesh Aggarwal, Assistant Director of MSME-DFO, Thrissur proposed vote of thanks during the inaugural function.



Presidential Address by Shri. G.S.Prakash IEDS, Joint Director & HoO



Lighting the lamp by dignitaries during the inaugural function



Address by Smt. Lachithamol U.C., Asst. Director and Program Coordinator, MSME-DFO, Thrissur

The whole sessions of the National Workshop has been divided into three technical sessions and details are as follows:

- i. Introductory Session on *"Scope in the International Market for MSMEs and Export Documentation Procedures"* has been handled by Shri. K.J. Bonniface, International Business Consultant.
- ii. The Technical session on the topic *"Emerging Opportunities in Export Market and Support from Government Organisations"* comprised of following sessions
 - a. The Role of DGFT in Promotion of Export Business- Shri.T.V. Stephen, Section Head, DGFT
 - b. Supports and Services from FIEO- Shri. Rajeev M.C., Head, FIEO, Kerala Chapter
 - c. Supports and Services from Office of DC(MSME)- Smt. Lachithamol U.C, Assistant Director, MSME DFO, Thrissur
 - d. Service through 'Dak Ghar Niryat Kendra – Shri. Sathyan, Marketing Executive, PMG Northern Region, Kozhikode.
 - e. Financial Support for Exporters from Banks – Shri. V.K. Adarsh Head, MSME Loan Point & Chief Manager Technical, Union Bank of India
 - f. Supports and Services from NSIC Ltd- Shri. Jeo John Chalakkal, Manager, Sub Branch Office, Thrissur
- iii. In the technical session on the topic *"Emerging Opportunities through Government E-Commerce Platforms"* the following sessions were included:
 - a. Open Network for Digital Commerce (ONDC) – Shri. Rahul Radhakrishnan, State Manager, Kerala, ONDC
 - b. Government e-Marketplace – Ms. Anamika Srivastava, Spokesperson, GeM
 - c. Opportunities through E-Commerce Platforms – Shri. Sreejith, Walmart Vridhi.



From Technical Sessions

The programme has been attended by 275 participants. The feedback received from the participants was good.



View of Participants

The participants of the National Workshop have made use of the facility of Help Desks and interacted with the Officials.



Help Desks

6.5 Activities of Export Facilitation Cell

The Export Facilitation Cell has been formed in the MSME-DFO as a dedicated support system for export promotion. The objective of EFC is to explore the untapped potential of MSME sector to boost export from domestic tariff area and special economic zones (SEZs) by promoting MSMEs and clusters in them. The EFC is facilitating existing and prospective MSMEs and clusters by providing handholding support and mentoring. EFC provides necessary guidance to MSMEs on export promotion, and import substitution. The EFC has supported exporters from MSME sector for getting their issues resolved. The Cell has provided necessary support to the prospective exporters in collecting statistics regarding the global market, identifying suppliers, guidance on the financial support schemes for export finance and supported for taking IE Code.

During the year, 1900 prospective and existing exporters supported by MSME-DFO, Thrissur through various activities related to export.

Chapter 7

Infrastructure Development and Cluster Development

The Ministry of Micro, Small and Medium Enterprises (MSME), Government of India (GoI) has adopted the Cluster Development approach as a key strategy for enhancing the productivity and competitiveness as well as capacity building of Micro and Small Enterprises (MSEs) and their collectives in the country. A cluster is a group of enterprises located within an identifiable and as far as practicable, contiguous area or a value chain that goes beyond a geographical area and producing same/similar products/complementary products/services, which can be linked together by common physical infrastructure facilities that help address their common challenges. One of the major objectives of the Scheme is to support the sustainability and growth of MSEs by addressing common issues such as improvement of technology, skills & quality, market access, etc. The scheme guidelines have been revised from existing project cost limit of 20 Crore to 30 Crore. The New Guidelines of MSE-CDP released vide OM No. 1(1247)/CDD/EFC/MSE-CDP/2021E dt 24.05.2023. The features of New MSE CDP Guidelines are as follows:

The funding pattern of Cluster projects with more than 50% Micro/ Village or Women owned or SC/ST owned unit or Aspirational District would be as follows:

Components	Total Project Cost	Funding Pattern		
		Govt. of India	State Govt	SPV
a. 1) Common Facility Centre(CFC)	Rs 5 crore to Rs 10crore	80%	15%	5%
2) Common Facility Centre(CFC)	Rs 10crore to Rs 30crore	70%	15%	15%
b. 1) Infrastructure Development New/Flatted Factory Complex	Rs 5 crore to Rs 15crore	70%	30%	-----
2) Infrastructure Development - Up gradation of existing Infrastructure	Rs 5 crore to Rs 10crore	60%	40%	-----

Followings are the key features as per the revised MSE-CDP guidelines:

- Minimum number of MSME units in SPV:
 - a) **CFC** project up to **Rs 10 Cr.**-10 units
 - b) **CFC** project from **Rs 10 Cr. to Rs 30 Cr.**-20 units
- As per the new guidelines project cost limit enhanced from Rs. 20 Cr. to Rs. 30 Cr.
- Project costing up to Rs **5 Cr.** is considered under **SFURTI Scheme** & from Rs 5 Cr. to Rs 30 Cr. under MSE –CDP
- Consultancy Charges to Technical Institution for preparation of DPR will be a sum equivalent to **4% of Project Cost** not exceeding **Rs 50 lakh**

- Cost of Land for CFC subject to max of **25%** of project cost
- CFC should be housed normally in Land/Building owned by SPV.
- CFC can be set up in, leased **land**, with a lease period of **25 years or more**.
- CFC can be set up also in **leased building** with lease period of **15 years or more**.
- For ID projects, land should be in the name of State Govt. /IA with Clear title.
- ID projects may be considered for road connecting private industrial estate to main road such as National Highways/ State highways.
- Fund Release Pattern in 3 installments in the ratio of **50:40:10**
- Project have to be completed within 18 months from date of approval by NPAC

7.1. Status of Implementation of MSE-CDP in Kerala

Kerala is among top 5 States in the Country in the effective implementation of MSE-CDP (CFCs & ID projects). Rs.209.2 Crores have been sanctioned to Kerala under the programme. 12 Common Facility Centres have already been commissioned and 8 Industrial Parks have been developed utilising these funds. Also 4 CFCs and 4 ID projects are under various stages of implementation in the State Kerala.

MSME-DFO is actively engaged in the promotion and development of clusters in the State in close liaison with the State Government and other stake holders. The status of activities under MSE-CDP for the year 2023-24 is as follows:

Table 7.1: Status of Activities under MSE-CDP 2022-23

i. CFC Projects – Commissioned

(Rs. in Lakhs)

Sl. No.	Name of Cluster	Contribution of Govt. of India	Contribution of Govt. of Kerala	Contribution of Consortium	Total Project Cost	Status
1	Rubber Cluster, Changanacherry, Kottayam	239.89	-	26.65	266.54	Commissioned June, 2007
2	Plastic Cluster, Aluva, Ernakulam	315.00	92.00	83.00	490.00	Commissioned February 2009
3	Terra Tile Cluster, Thrissur	249.65	99.86	149.79	499.30	Commissioned January 2010 (CFC is not functioning due to lack of raw material)
4	Plywood Cluster, Perumbavoor, Ernakulam	235.31	67.23	114.69	417.23	Commissioned January 2010
5	Rice Millers Cluster, Kalady,	472.84	162.72	77.84	713.40	Commissioned December 2011

Ernakulam							
6	Kerala Furniture Cluster, Perumbavoor, Ernakulam	245.29	98.12	147.17	490.58	Commissioned September 2010	Flood affected the cluster and damage occurred to machineries and raw material.
7	Wood Cluster, Perinthalmanna, Malappuram	160.23	45.78	32.89	238.90	Commissioned July 2012	
8	General Engineering Cluster, Manjeri, Malappuram	199.00	63.00	53.01	315.01	Commissioned January 2015	
9	Wood Cluster, Chadayamangalam, Kollam	181.67	51.91	25.95	259.53	Commissioned May 2017	
10	Offset Printing Cluster, Kannur	855.50	244.43	122.21	1,222.14	Commissioned March 2018	
11	Wood Furniture Cluster, Taliparamba, Kannur	811.67	235.38	117.69	1,164.74	Commissioned December 2018	
12	Furniture Cluster, Thrissur (<i>Thrissur Traditional Furniture Cluster Chevoor Pvt. Ltd.</i>)	1,002.46	289.01	153.61	1,445.08	Commissioned January 2021	
Total		4968.51	1449.44	1104.5	7522.45		

ii. CFC Projects - On going*(Rs. in Lakhs)*

Sl. No.	Name of the Project	Contribution of GoI	Contribution of GoK	Contribution of Consortium	Total Cost
1	Plywood Cluster, Idukki Parliament Constituency, Ernakulam District <i>(West Malabar Plywood Manufacturers Cluster Services Pvt. Ltd.)</i>	982.884	280.824	140.412	1,404.12
2	Furniture Cluster, Kozhikode	1012.69	289.34	144.67	1,445.08
3	Kalady Steel Consortium, Ernakulam	1050	300	241.27	1591.27
4	Papadam Cluster, Thiruvananthapuram	382.41	111.04	61.77	555.22
	Total	3,427.984	981.204	588.122	4997.31

iii. ID Projects - Completed Industrial Estates*(Rs. in Lakhs)*

Sl. No.	Name of the Project	GoI	GoK	Total Cost
1	New Industrial Estate at Kazhakuttam Distt. Thiruvananthapuram	200.00	302.00	502.00
2	KINFRA Small Industries Park, Kasaragod	194.00	373.00	567.00
3	KINFRA Small Industries Park, Wayanad	189.60	310.40	500.00
4	KINFRA Small Industries Park, Thalassery, Kannur	196.00	382.79	578.79
5	KINFRA IIDC, Malappuram	200.00	403.00	603.00
6	KINFRA Small Industries Park, Koratty, Thrissur	184.06	315.94	500.00
7	KINFRA Small Industries Park, Mazhuvannur, Ernakulam,	178.00	320.00	498.00

8	KINFRA Small Industries Park, Adoor, Pathanamthitta,	278.98	186.02	465.00
9	Spices Park, Idukki	576.95	673.05	1250
10	Rubber park, Ernakulam	582.6	388.4	971
Total		2780.19	3654.60	6434.79

iv. Ongoing ID Projects

(Rs. in Lakhs)

Sl No	Industrial Estate	GoI sanction	GoK sanction	Total
1	Poovanthuruth Industrial Area	600	400	1000
2	Edayar Industrial Estate	580.614	387.076	967.69
3	KINFRA International Apparel Park(KIAP), Thiruvananthapuram	505.54	337.03	842.57
4	KINFRA Ind. Estate Kunnamthanam	339.54	366.70	706.24
5	KINFRA Ind. Estate (Textile Centre) Kannur	452.11	555.39	1007.50
6	KINFRA Ind. Estate (Food Processing) Adoor	454.85	544.16	999.01
Total		2932.654	2590.356	5523.01

7.2. Important Activities Undertaken by MSME-DFO, Thrissur to Implement MSE-CDP in the State

- Shri. G.S.Prakash, JD & HoO of MSME-DFO, Thrissur & AD/CDO attended all the NLSC meetings Chaired by Secretary (MSME) & AS & DC and presented various projects from Kerala and also other matters related to implementation of MSE-CDP. NLSC accorded approval for 4 new ID projects under MSE-CDP.



- State Level Review meetings to review the ongoing MSE-CDP projects:** MSME-DFO, Thrissur regularly convened the State Level Review meetings to review the progress of the ongoing MSE-CDP projects in the State. These meetings were chaired by Shri. Suman Billa IAS, Principal Secretary (Industries) Govt. of Kerala and was attended by all stakeholders. Senior officers from the Directorate of Industries, GoK, Joint Director & HoO MSME DFO, AD & CDO of MSME - DFO, GMs of DICs, CEO of KBIP, MD of KINFRA, SPV members, technical experts and other stake holders attended these meetings. MSME-DFO prepared the agenda after getting inputs from all stakeholders and made PPT based presentation on the status of the projects during these meetings. Minutes of the meeting approved by the principal secretary (Industries) was forwarded to all stakeholders for further necessary action.

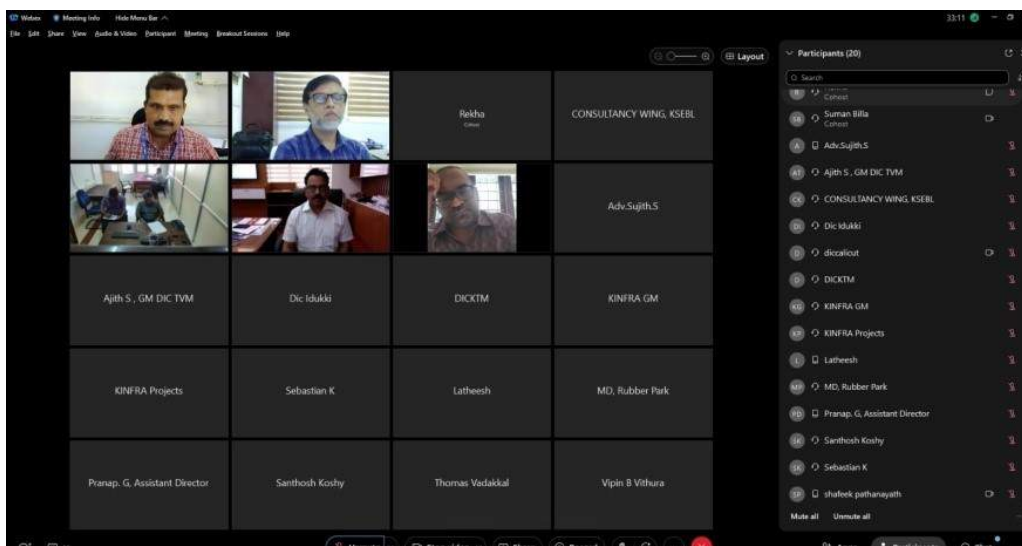

Shri. Suman Billa IAS, Principal Secretary (Industries) Govt of Kerala chaired regular review meetings to review the progress of the ongoing projects under MSE-CDP

- State Level Steering Committee (SLSC) Meeting of MSE-Cluster Development Programme** for Kerala was held on 17.08.2022 under the Chairmanship of Shri. Suman Billa IAS, Principal Secretary Industries, Government of Kerala. Shri. G S Prakash Joint Director/HoO & Member Secretary SLSC along with AD&CDO MSME-DFO, Thrissur coordinated the meeting. SLSC has approved the DPR of Wood Cluster Kottayam. SLSC also approved DPRs for New ID Projects at Industrial Estate Kunnamthanam, Pathanathitta, Industrial Estate Kochuveli, Thiruvananthapuram, Industrial Estate in Aroor, Alappuzha. DPR of KINFRA International Apparel Park Kazhakuttom Thiruvananthapuram along with SLSC approval was forwarded to O/o DC (MSME) New Delhi for considering the same under MSE CDP Old guidelines.



Shri. Suman Billa IAS, Principal Secretary Industries, Government of Kerala Chairing the State Level Steering Committee (SLSC) Meeting of MSE-Cluster Development Programme (MSE -CDP) for the State of Kerala.

- Joint Director & HoO visited KINFRA Apparel Park, Kazhakoottam, Thiruvananthapuram on 18.05.2023. He had a meeting with the Managing Director, Apparel Park and President of KINFRA Park Industries Association. He visited few units in the Park. KINFRA submitted their DPR for Infrastructure Development of this park under MSE-CDP Scheme of M/o MSME. He discussed with the members of the park and industrial association about the DPR submitted under MSE-CDP and assessed their requirements. MSME-DFO, Thrissur recommended the DPR to the Ministry of MSME and the project got the final approval of NLSC.
- Joint Director & HoO attended the Foundation stone laying ceremony of the CFC building for the Papad Cluster at Thiruvananthapuram on 02.06.2024. The CFC is funded under the MSE-CDP Scheme of M/o MSME, Government of India. The Foundation stone laying ceremony was performed by Shri P Rajeeve, Hon'ble Minister for Industries, Govt of Kerala in the presence of Shri Antony Raju Hon'ble Minister for Transport, Govt of Kerala at Veli Industrial Estate, Kochuveli, Thiruvananthapuram. Shri Suman Billa, Principal Secretary (Industries), Govt of Kerala & other senior officers from Industries Department, SPV members etc participated in the function. Joint Director & HoO addressed the gathering and informed about the assistance provided to clusters in the state under MSE-CDP scheme of state

Government. The total approved project cost of the CFC is Rs 555 lakhs in which Govt of India share is Rs 382 lakhs (about 70%), Government of Kerala share is Rs 111 lakhs and the share of M/s Ananthapuram Papad cluster association (SPV) is Rs 61 lakhs. This project is implemented by K-BIP under the Industries department of Government of Kerala. Joint Director also visited 4 Papad making units in the cluster and attended an interactive meeting of SPV members.



Hon'ble Industries Minister, Govt of Kerala, Shri P Rajeeve, performing Foundation stone laying ceremony of the CFC for Papad cluster in the presence of Shri Antony Raju Hon'ble Minister for Transport, Govt of Kerala, Shri Suman Billa, Principal Secretary (Industries), Govt of Kerala, Shri GS Prakash Joint Director & HoO, MSME-DFO Thrissur, Shri Abraham Chairman M/s Ananthapuram Papad cluster association (SPV) MD & other senior officers from industries department



JD & HoO addressing the gathering during Foundation stone laying ceremony of the CFC for Papad cluster

- Joint Director & HoO had discussion with Hon'ble Industries Minister, Govt. of Kerala, Principal Secretary (Industries) & Director of Industries, CEO K-BIP on 2/6/2022, 22/6/2023 & 26/6/2023 regarding progress & constraints in implementing 8 ongoing projects under MSE-CDP in the state & requested for their intervention for timely implementation of the projects.
- Joint Director & HoO along with AD/CDO attended the inaugural function of Spices Park at Idukki District under 14.10.2023. Hon'ble Chief Minister of Kerala Shri Pinarayi Vijayan inaugurated the Spices Park. Hon'ble Minister of Industries and Commerce Shri. P. Rajeev presided over the function. Hon'ble Minister of Water Resources Shri. Roshi Augastine was the Guest of Honour. The spices park was financially supported under the ID component of MSE-CDP scheme of Ministry of MSME, Govt. of India.



Inauguration of Spices Park which was supported under the ID scheme of MSE-CDP by Shri Pinarayi Vijayan, Hon'ble Chief Minister, Govt. of Kerala

- Joint Director & HoO along with AD/CDO visited M/s West Mount Coffee manufacturers on 07.02.2024 at KINFRA Small Industries Park, Kalpetta, Wayanad and discussed with the Tea/Coffee processing units about the MSE-CDP Scheme, M/o MSME, Government of India.



JD & HoO during the visit at M/s West Mount Coffee manufacturers at KINFRA Industries Park, Wayanad

- Land for a New Technology Centre, Thiruvananthapuram:** Shri. G.S.Prakash, JD & HoO (on behalf of DC (MSME)) and Shri Suresh Kumar K., Secretary Registrar, Electronics Technology Parks-Kerala (Technopark) (on behalf of Government of Kerala) signed the Deed of Lease on 19.01.2024 for the transfer of nearly 10 acres of land on lease for 90 years on perpetual basis from the State Government to DC-MSME for the establishment of Technology Centre under TCEC Scheme at Ministry of MSME at Thiruvananthapuram.



Handing over the Deed of Lease for the new TC in the presence of Sub Registrar, Murukkumpuzha



On 20.01.2024, Shri Sanjeev Nair, CEO Technopark, Thiruvananthapuram handed over the original Land Lease agreement to Shri G S Prakash, Joint Director & Head of office, MSME-DFO Thrissur, Ministry of MSME, Government of India in the presence of Dr. Rathan U Kelkar IAS Secretary, E & IT, Government of Kerala & Shri. Levin, CEO, Space park, for the proposed Technology Centre, Thiruvananthapuram .

- JD & HoO and Assistant Director (Electrical) attended the Consultative Meeting on the proposed Technology Centre at Thiruvananthapuram on 24.01.2024 under the chairmanship of Shri G Levin, CEO, K-Space. Dr. Ratan U Kelkar, IAS, Secretary Electronics & IT, Government of Kerala, Dr. Saji Gopinath, Vice Chancellor, Kerala University of Digital Sciences, Innovation & Technology, Shri Masoor Ahmad, CGM, IRCON International Limited and other stakeholders attended the meeting. JD & HoO presented an overview of the setting up of Technology Centres all over the country under TCSP and TCEC Schemes of the Ministry of MSME, Government of India. JD & HoO thanked Govt. of Kerala for allotting 10 Acres of Land on lease for the project. Detailed group discussions were held among the Stakeholders who attended the meeting and Valuable inputs were received from Stakeholders. MSME-DFO, Thrissur later submitted to O/o DC-MSME a detailed report on the inputs from the stake holders regarding the facilities required at TC.



Chapter 8

Entrepreneurship and Skill Development Assistance to Entrepreneurs

Entrepreneurship development is the process of improving the skills and knowledge of entrepreneurs, enhancing the capacity to develop, manage and organize a business venture while keeping in mind the risks associated with it. The whole point of entrepreneurship development is to increase the number of entrepreneurs. Ministry of MSME has been organizing a number of Entrepreneurship and skill development programmes for the existing & potential entrepreneurs, in order to build their capacity to take up successful ventures.

The objective of the programme is to motivate youth representing different sections of the society including SC/ST/Women, differently-abled, Ex-servicemen and BPL persons to consider self-employment or entrepreneurship as one of the career options. The ultimate objective is to promote new enterprises, capacity building of existing MSMEs and inculcating entrepreneurial culture in the country.

8.1. Activities under ESDP Scheme

During the year 2023-24, the MSME-DFO, Thrissur has organized the programmes as per the allocation from O/o DC (MSME), in such way that the MSMEs will be benefited. The targets assigned to MSME-DFO, Thrissur and the achievements against this target are as follows:

Table 8.1: Status of the Programmes 2023-24

Name of Training	Target	Achievement	Trained	Fund Sanctioned (Rs.)	Expenditure Incurred (Rs.)
EAP - Gen	40	40	3659	8,00,000	7,96,456
EAP - SC	14	14	1239	2,80,000	2,77,523
EAP - ST	2	2	142	40,000	39,985
E-SDP - Gen	15	15	396	18,75,000	18,72,548
E-SDP - SC	2	2	47	2,50,000	2,49,240
E-SDP - ST	1	1	30	1,25,000	1,24,989
MDP - Gen	10	10	269	5,00,000	4,92,756

MDP - SC	1	1	28	50,000	49,990
Total	85	85	5810	3920000	3903487

From the above it is evident that MSME-DFO has successfully achieved the targets allotted.

8.1.1. Publicity of the Programmes under ESDP Scheme

The programmes were focused for prospective and existing entrepreneurs. Brochures and posters for the publicity have been prepared for wide circulation through social media platforms like Official Facebook and Twitter pages; various WhatsApp groups of Stakeholders. Apart from that, to make the benefit of the programme reach to prospective and existing entrepreneurs in the State, the District Industries Centres and Financial Institutions were informed about the programme to get the details of applicants of PMEGP Scheme and the interested persons were requested to submit their registration through a Google Form or by email/WhatsApp messages. Further, DAVP advertisements/press releases have been given. Based on these publicity measures, this Office have received a large number of enquires and selected prospective entrepreneurs were given entry to the programmes.

Government of India
Ministry of Micro, Small and Medium Enterprises
MSME-Development & Facilitation Office, Thirissur

In association with
Mar Baselious Christian College of Engineering & Technology, Peerumedu

സംരംഭകത്വ ബോധവൽക്കരണ ശില്പശാല

Date: 13th October 2023 @
മാർ ബസേലിയസ് ക്രിസ്ത്യൻ കോളേജ് ഓഫ് എഞ്ചിനീയറിംഗ് & ടെക്നോളജി പീരൂമേട്

കൂടുതൽ വിവരങ്ങൾ
സംരംഭകത്വ നടത്തിക്കൊണ്ടു പോകുന്നതിനുള്ള മാർഗ്ഗ നിർദ്ദേശങ്ങൾ സംരംഭകർക്ക് സാമ്പത്തിക സഹായങ്ങൾ നൽകുന്ന ഏജൻസികളെ കുറിച്ചുള്ള വിവരങ്ങൾ.
വിവിധ സർക്കാർ സംരംഭകത്വപദ്ധതികളെ കുറിച്ചുള്ള വിവരങ്ങൾ

പങ്കെടുക്കാൻ താല്പര്യമുള്ള 18 വയസ്സ് പൂർത്തിയായവർ താഴെ കാണുന്ന ലിങ്ക് വഴിയോ അല്ലെങ്കിൽ WhatsApp നമ്പരിലോ പോർ, യേശുവിടാസം എന്നിവ ഒക്ടോബർ 11 നു മുൻപായി അയച്ചു തരേണ്ടതാണ്

പ്രവേശനസൗജന്യം -
രജിസ്ട്രേഷൻ നിർബന്ധം-<https://bit.ly/EAPMBCC>

കൂടുതൽ വിവരങ്ങൾക്ക്: Smt.Rekha.K, Programme Coordinator, MSME-Development & Facilitation Office, Ministry of Micro, Small and Medium Enterprises, Ayyanthole P.O, Thirissur; Tel: 0487-2360536
WhatsApp number: 7559008308; Email: invkr.tcr-msmedi@gov.in

Government of India
Ministry of Micro, Small and Medium Enterprises
Office of Development Commissioner (MSME)

MSME-Development and Facilitation Office, Thirissur
In association with People's Foundation, Kozhikode

Management Development Program (MDP)

Capacity building in Export business

20th to 25th November 2023
@ Centre for Information and Guidance India- CIGI, Kozhikode

Registration fees : 500/-
Last Date to Apply: 2023 November 15

To Register:
Scan the QR Code or submit details @
<https://forms.gle/y65bb6va3ECKDqzC9>
or WhatsApp (for details) to
8330080536
(Name, Address, Mobile Number, Email address, Course Name, etc.)

Government of India Certificate on Successful Completion of the Course

For more details contact:
Email: adicm.tcr-msmedi@gov.in
Mob: 8113898003, 8330080536, 7042755898
Tel: 0487-2360536, 2360686

Government of India, Ministry of Micro, Small & Medium Enterprises
MSME-Development & Facilitation Office (DFO), Thirissur
In association with
GSR Management Consultants Pvt. Ltd.

MANAGEMENT DEVELOPMENT PROGRAMME ON 'Scaling Up of Business'	
Duration	5 Days, From 11th December, 2023 to 15th December, 2023
Venue	MSME DFO Thirissur, Kanjani Road, Thirissur
Eligibility	Manufacturing or Service Enterprise started in the last five years
Fees	Rs. 500/-
Available Seats	25
Last Date of Registration	05.12.2023
Fill the registration link https://bit.ly/MDP-SCALINGUP	
Sessions will be on	
<ul style="list-style-type: none"> Business Plan, Mission, Vision Organizational Structure Meetings, Agenda, Decision, Time Management Business functions - Production to Sales Power of Strategic thinking Why Startups fail & how to make them succeed Partnerships - Reasons for failure Taxation - Direct & Indirect Banks - Types of loans and features Personal & Business Finances SWOT analysis 	<ul style="list-style-type: none"> Finance & Accounting Accounting software and their limitations Accountants & Auditors Financial Statements & their purposes and analysis - Liquidity Solvency Ratios Performance Audits Sales & Marketing Digital Marketing & Innovative Technologies (AI, IOT etc.) Branding & Intellectual Property Rights Fraud & Organizational Culture Prevention, Detection, Investigation of Frauds

For details contact:
Vishesh Aggarwal, Program Coordinator, MSME-DFO, Thirissur
Mobile: 9873711189, Tel: 0487-2360536; 2360686

Government of India
Ministry of Micro, Small and Medium Enterprises
MSME Development & Facilitation Office, Thirissur
In association with
ESAF Foundation
ENTREPRENEURSHIP SKILL DEVELOPMENT PROGRAMME
ON
SOLAR PV POWER SYSTEM
From - 9th October 2023

- Duration: 6 Weeks; From 9th October 2023
- Age: Between 18-40
- Course Fee: Rs. 500/- for General candidates. No fee for SC/ST/Women/PH/Ex-service men/BPL category
- Qualification: ITI/ DIPLOMA/ B-Tech in Electrical/ Electronics/ Practised Electricians/ Mechanics etc.
- No. of Seats: Maximum 25
- Venue: MSME Development & Facilitation Office, Thirissur
- Registration: Click - <https://bit.ly/esdpolar> or scan QR code

COURSE CONTENT: Introduction to Solar PV System, Basic Electrical and Electronics, Load Calculation and Capacity Assessment, Batteries, Solar PV Panels, Cables and Protective Devices, Electrical wiring, Inverter-OFF/ON Grid, Marketing aspects, Entrepreneurship, Other Policies & schemes of Central and State Government to start own business, Solar Installation, Practical and Site Visit.

For more details: Shri.P B Suresh Babu: EDS, Assistant Director, Mob: 9494078403, Shri.Shaji N M Mob: 9494216921, Shri.Sebastian K J Mob: 9995459719, MSME Development and Facilitation Office, Thirissur, Ministry of MSME, Government of India 0487-2360536, 2360686, 2973636. Email: dcuf-thrissur@msme.gov.in, Shri.Vishakh Mohan, ESAF Foundation- 96569 18339

MSME-DEVELOPMENT & FACILITATION OFFICE, AYYANTHOLE P.O, THIRISSUR-680003

A few Publicity Posters

The details of programmes organized for the entrepreneurship developments are explained below:

8.1.2. Entrepreneurship Awareness Programmes (one Day)

As per the revised Scheme guidelines of ESDP Scheme, the One Day Entrepreneurship Awareness Programmes are organized as an activity to identify and motivate traditional/non-traditional entrepreneurs, having potential for setting up MSEs with an objective of leading them towards entrepreneurship/self-employment. The programme has technical sessions and one-to-one discussions with interested participants for counselling and mentoring, which will impart knowledge to the trainees to start and run their own enterprises successfully.

As per Sanction order from Office of DC-MSME, New Delhi, MSME-DFO, Thirissur has been allotted with 56 Number of EAPs, including 14 SC Programmes and 2 ST programmes. Immediately on the receipt of the Sanction, MSME-DFO, Thirissur has initiated action to implement the programme effectively with the main objectives to create awareness about the importance of entrepreneurship and thus being job providers than job seekers, to create awareness about various support from Central and State Governments, and Financial institutions, to provide entrepreneurial motivation, to provide tips to prepare project reports, and to help them to find suitable sectors which are having potential in the State and to provide mentoring and future handholding.

8.1.2.i. Major Common Features of the EAPs Organised by MSME-DFO, Thirissur

MSME-DFO, Thirissur has approached the programmes as one of the major assignments of the year and intended to utilize the same to awake the prospective entrepreneurs in the State by giving motivation to achieve their goals with the support of various Schemes and

Support from Central and State Government Departments and financial institutions. Followings are the major common features of the programmes organized:

- i. The programmes were carried out in association with various State Government Organizations, like District Industries Centers, various Local Self Government Departments, SHGs, Industrial Associations, SC/ST Association, and also by utilizing the expertise and infrastructure facilities of prominent Academic Institutions.
- ii. Participants selected were prospective entrepreneurs and existing entrepreneurs who just started the business
- iii. Each programme had a session on experience sharing by the successful entrepreneurs

Sessions	Topics	Panel of Experts
Session 1 (9.30 am 11.00 am)	Motivation for Prospective Entrepreneurs Achievement Motivation/Opportunity Identification - Orienting a person towards continuous self-appraisal Entrepreneurship Motivation and Mentoring <i>Or</i> <i>Experience Sharing by Successful entrepreneur and also Case studies on failure.</i>	Expert/Certified Trainer/ Entrepreneurs/MSME-DFO Officer/Consultant
Step by Step Procedures for Establishing an Enterprise		
Session 2 (11.00 am to 12.30 pm)	Support for Entrepreneurs from Government of Kerala	Official from Respective DIC
Session 3 (12.30 pm to 1.00 pm)	Support for Entrepreneurs from Govt. of India	Programme Coordinator, MSME-DFO, Thrissur
Session 4 (1.00 pm to 2.30 pm)	Assistance from Financial Institutions/Alternative Sources	Lead Bank representative/FLC/RSETI Officials/SME Branch/Financial Experts/FLCs
Session 5 (2.45 pm to 4.00 pm)	Entrepreneurship opportunity guidance and one to one interaction to enable each participant to clear his/her doubts	Panel of DIC Official/Financial Institution/MSME-DFO
Session 6 (4.00 pm to 4.30 pm)	Collecting feedback (as per the specific feedback form)	Programme Coordinator, MSME-DFO, Thrissur
Concluding address		

The following table shows the details of the EAPs organized.

Table 8.2.: Details of EAPs conducted during the year 2023-24

Sl No	Type of Programme	Place	Date	Male	Female	Total No of Participants
1	EAP – Gen	MSME-DFO, Thrissur	22.09.2023	77	18	95
2		Pattambi	26.09.2023	40	50	90
3		Idukki	26.09.2023	5	99	104
4		Alappuzha	08.10.2023	211	36	247
5		Kuttikkanam, Idukki	13.10.2023	43	22	65
6		Kodungallur	10.10.2023	74	75	149
7		Pulikkalodi, Malappuram	12.10.2023	48	22	70
8		Tirur, Malappuram	13.10.2023	4	74	78
9		Mananchira, Kozhikode,	13.10.2023	85	10	95
10		Thodupuzha, Idukki	15.10.2023	127	32	159
11		Guruvayur	17.10.2023	55	12	67
12		Chengannur	20.10.2023	76	14	90
13		Malappuram	26.10.2023	51	4	55
14		Aruvithura, Kottayam	27.10.2023			63
15		Thrissur	30.10.2023	42	16	58
16		Malom, Kasaragod	03.11.2023	73	21	94
17		Kollam	10.11.2023	0	122	122
18		Vaikom	10.11.2023	12	108	120
19		Adimali - Idukki	17.11.2023	7	89	96
20		Guruvayur	21.11.2023	25	26	51
21		Cherthala	22.11.2023	0	116	116

22		MSME DFO Thrissur	22.11.2023	58	13	71
23		Olarikkara,Thrissur	24.11.2023	0	82	82
24		Thalassery, Kannur	30.11.2023	5	69	74
25		Nalanchira, Thiruvananthapuram	01.12.2023	34	73	107
26		Mangattuparambu, Kannur	02.12.2023	106	9	115
27		Talap, Kannur	03.12.2023	115	5	120
28		Payyannur, Kannur	08.12.2023	44	31	75
29		Kalady, Ernakulam	17.12.2023	58	9	67
30		Manjapra, Angamaly	19.12.2023	38	14	52
31		MSME DFO Thrissur	17.01.2024	46	5	51
32		Pudur	25.02.2024	34	37	71
33		Palakkad	11.03.2024	73	12	85
34		Kodungallur	13.03.2024	43	34	77
35		Edappal, Malappuram	13.03.2024	44	28	72
36		Edappally, Ernakulam	16.03.2024	53	23	76
37		Thalakkottukara, Thrissur	18.03.2024	56	30	86
38		Aloor	16.03.2024	57	44	101
39		Koyilandi	02.03.2024	44	53	97
40		Kanichikulangara, Alappuzha	20.03.2024	26	68	94
Total (Gen)				2019	1638	3657
EAP - SC						
1		Erumapetty	25.09.2023	58	32	90
2		Vettukkad, Thrissur	19.10.2023	26	48	74
3		Thrissur	26.10.2023	113	15	128

4	Kanhangad, Kasaragod	02.11.2023	39	53	92
5	Pattanchery, Palakkad	21.11.2023		71	71
6	Peringanur	15.12.2023	43	42	85
7	Peringottukurissi, Palakkad	19.12.2023	16	96	112
8	Sulthan Bathery, Wayanad	11.01.2024	33	110	143
9	Kurichy, Kottayam	13.01.2024	33	80	113
10	Vavanoor	02.02.2024	46	24	70
11	Peringammala, Thiruvananthapuram	17.02.2024	50	9	59
12	Ponnani	22.02.2024	12	80	92
13	Irumpayam, Kottayam	24.02.2024	40	65	105
14	MSME-DFO, Thrissur	01.03.2024	11	48	59
Total (SC)			520	773	1293
EAP-ST					
1	Kottopadam, Palakkad	04.11.2023	55	20	75
2	Agaly, Palakkad	24.02.2024	18	49	67
Total (ST)			73	69	142
Grand Total (56 Programmes)			2612	2480	5092

A few photographs of the EAP programmes are as follows:



Inauguration of an EAP



Presidential Address by JD & HoO in of one of the EAPs, conducted for the differently abled persons



From one of the Technical Sessions of an EAP



From one of the Technical Sessions of an EAP



View of the Participants of an EAP

എസ്.എൻ.ജി. എൻ.ജി. കോളേജിൽ സംരംഭകത്വ ബോധവൽക്കരണ ശില്പശാല സംഘടിപ്പിച്ചു

പട്ടണൂർ: ശ്രീനാരായണ ഗുരു കോളേജ് ഓഫ് എഞ്ചിനീയറിംഗ് ആൻഡ് ടെക്നോളജിയിൽ യുവ സംരംഭകർക്കായി സംഘടിപ്പിച്ച "സംരംഭകത്വ ബോധവൽക്കരണ ശില്പശാല" റോംകോൺട്രിബ്യൂട്ടഡ് ട്രൈംഗിൾ കോർസ് ഉദ്ദേശ്യം ചെയ്തു. ശ്രീ രാജി സംരംഭകത്വ ബോധവൽക്കരണ ശില്പശാലയുടെ ഉദ്ദേശ്യം ചെയ്തു. കോളേജിന്റെ സഹായത്തോടെ സംരംഭകത്വ ബോധവൽക്കരണ ശില്പശാലയുടെ ഉദ്ദേശ്യം ചെയ്തു. കോളേജിന്റെ സഹായത്തോടെ സംരംഭകത്വ ബോധവൽക്കരണ ശില്പശാലയുടെ ഉദ്ദേശ്യം ചെയ്തു. കോളേജിന്റെ സഹായത്തോടെ സംരംഭകത്വ ബോധവൽക്കരണ ശില്പശാലയുടെ ഉദ്ദേശ്യം ചെയ്തു.



Media Coverage of an EAP

8.1.3. Entrepreneurship-Cum-Skill Development Programmes (E-SDP)

This six weeks activity is aimed at conducting special entrepreneurship development programmes for new livelihood enterprise creation and rural enterprise development. This is a product-cum-process oriented activity-based programme. Comprehensive training programmes were organized to upgrade skills of prospective entrepreneurs coupled with specific skills. hands on practice or demonstration relating to activities. MSME-DFO, Thrissur organized 18 E-SDPs during the year 2023-24, including 2 SC and 1 ST programmes.

These programmes were organised in association with reputed organisations and expert faculties for the benefit of prospective and existing entrepreneurs. The details of the programmes are tabulated below:

Table 8.3: Details of E-SDPs conducted during the year 2023-24

Sl No	Programme Type	Venue and Topic	Date	Male	Female	Total
1	E-SDP (Gen)	MSME-DFO, Thrissur, 'Milk and Confectionary Products'	18.09.2023 to 31.10.2023	8	18	26

2	MSME-DFO, Thrissur - 'Fabric & Glass Painting'	18.09.2023 to 31.10.2023	3	30	33
3	MSME-DFO, Thrissur- 'Basic and Advanced Welding'	25.9.2023 to 8.11.2023	27	NIL	27
4	International institute of Wellness and Hospitality, Thiruvananthapuram 'Beauty and Spa Therapy'	25.09.2023 to 07.11.2023	9	13	22
5	MSME DFO, Thrissur on 'Solar Photovoltaic Power System'	09.10.2023 to 21.11.2023	22	3	25
6	Ansar College, Perumpilavu - 'Graphic Designing'	16.10.2023 to 28.11.2023	13	19	32
7	SSM Polytechnic College, Tirur, 'Garment Stitching(Professional Uniform)'	16.10.2023 to 23.11.2023		30	30
8	St. Antonys College Peruvanthanam, Fashion Designing	16.10.2023 to 12.12.23	0	26	26
9	Mushroom Folks Academy, Kozhikode, 'Training on Information Technology'	30.10.2023 to 06.12.2023	15	6	21
10	3rd Eye Security System, Thrissur, 'Extra Low Voltage systems and Solar'	06.11.2023 to 11.12.2023	17	0	17
11	MSME-DFO, Thrissur- 'Basic and Advanced Welding'	13.11.2023 to 22.12.2023	29	0	29
12	T.A.P.M Industrial School, Cherthala, 'Garment Manufacturing'	15.11.2023 to 19.12.2023	0	26	26

13		MSME-DFO, Thrissur, 'Ready to eat/cooked food'	27.11.2023 to 05.01.2024	6	20	26
14		Mount Seena College, Lakkidi, 'Tally and Basic Accounting For Commercial Practice'	04.12.2023 to 20.01.2024	12	17	29
15		MSME DFO Thrissur on 'Basic and Advanced Welding'	21.12.2023 to 13.02.2024	27	0	27
Total (Gen)				188	208	396
1	E-SDP (SC)	Nellikatta, Kasaragod, 'Food Processing'	07.12.2023 to 15.01.2024	2	21	23
2		Idukki - 'Hand Embroidery, Mural Painting, Jewellery Making'	29.11.2023 to 10.01.2024	-	24	24
Total (SC)				2	45	47
1	E-SDP (ST)	Viswasanthi Development Foundation, Adimali 'Artificial Jewellery making, Saree Mural painting and Textile Printing'	13.11.2023 to 22.12.2023	0	30	30
Total (SC)				0	30	30
Grand Total (18 programmes)				190	283	473

A few photographs from the E-SDP programmes are as follows:



From the Inauguration of an E-SDP Programme



From the practical session of an E-SDP Programme



From the practical session of an E-SDP Programme



From the Exhibition of Trainees Products



Products Prepared by Trainees



Media Coverage of an E-SDP



Participants of an E-SDP with Guests

8.1.4. Management Development Programmes (MDPs)

This one week activity is aimed at capacity building of existing and prospective entrepreneurs through inputs on management practice system is to improve their decision-making capabilities resulting in higher productivity and profitability of existing and potential entrepreneurs and developing new enterprises.

MSME-DFO, Thrissur organized 11 MDPs during 2023-24 for the benefit of prospective and existing entrepreneurs, with special focus on scaling up of their business. Topics of each session of MDPs were prepared in such a manner that it will be beneficial for the participants. And all the programmes were either in association with reputed management institutions in the State or with the expert faculties. The details of the programmes are tabulated below:

Table 8.4: Details of MDPs conducted during the year 2023-24

Sl No	Programme Type	Venue and Topic	Date	Male	Female	Total
1	MDP (Gen)	Gulati Institute of Finance and Taxation (GIFT), Thiruvananthapuram – 'Taxation'	25.10.2023 to 31.10.2023	20	5	25
2		Kozhikode - 'Capacity Building in Export Business'	20.11.2023 to 24.11.2023	32	8	40
3		Leads College of Management, Dhoni, 'Digital marketing'	11.12.2023 to 15.12.2023	22	4	26
4		MSME-DFO, Thrissur, 'Scaling Up of Business'	11.12.2023 to 15.12.2023	15	5	20
5		Thodupuzha 'Up-Scaling of MSMEs'	17.01.2024 to 23.01.2024	21	4	25
6		Kochi - 'Capacity Building in Export Business'	20.01.2024 to 02.02.2024	20	4	24
7		Kochi - 'Supply Chain Management'	24.01.2024 to 31.01.2024	18	9	27

8		MSME-DFO, Thrissur, 'Financial Management and Taxation for MSMEs'	19.02.2024 to 23.02.2024	19		27
9		LAM Knowledge Centre, Malappuram, 'Marketing And Supply Chain Management'	04.03.2024 to 08.03.2024	24	1	25
10		KMA Hall Ernakulam on 'Financial Management and Taxation'	11.03.2024 to 15.03.2024	23	7	30
Total (Gen)				194	42	244
1	MDP (SC)	Jawaharlal College of Engineering Technology Lakkidi, Palakkad 'Emerging Paradigms in Marketing'	15.01.2024 to 19.01.2024	22	6	28
Total (SC)				22	6	28
Grand Total (11 Programmes)				216	48	272

A few photographs from the MDP programmes as are follows:



From the Inauguration of an MDP Programme



From a technical session



From a technical session



From Certificate Distribution



From one of the Valedictory Function



Participants of an MDP

8.2. Faculties and Participants

Eminent people made deliberations in the above mentioned programmes. Each programme had four sessions in each day. The total number of participation in the programmes was 5810. The participants were comprised of existing and prospective entrepreneurs. All the sessions were very interactive with active participation of the participants.

8.3. Feedback of the Programmes

At the end of the programmes, feedback from the participants was collected through feedback form for physical programmes. As per the feedback received from the participants, the programmes were really vibrant and beneficial. As per the feedback, the course content/information was excellent and duration of the sessions were sufficient and all stated that they were interested in participating in similar programmes.

8.4. Outcome of the Programmes

The programmes have created awareness among the prospective and existing entrepreneurs to understand basics on bankable project report preparation, services provided by Financial Institutions, Industries Department, GoK, M/o MSME etc. and imparted specific skills to set up their own enterprises and to manage their enterprises to scale up the business. Need based handholding support is being provided to participants from MSME-DFO, Thrissur.

Various programmes organized by MSME-DFO, Thrissur under ESDP Scheme during the year 2023-24 have resulted in providing entrepreneurial development which instilled self-confidence in stakeholders which will result in increase in their competence to perform to the best of their ability and thus lead them to be proactive to the swings in the market.

Chapter 9

Grievance Redressal, Publicity and Out Reach Programmes

Apart from the flagship activities and support under Schemes of the Ministry of MSME, the MSME-DFO, Thrissur has taken several initiatives for the welfare of the MSME Sector based on the time to time instructions from Office of Development Commissioner (MSME). The Chapter puts light on those activities.

9.1. Champions Portal – The Grievance Redressal Mechanism

The State Champion Control Room started operation on 11th May, 2020 in the premises of MSME-DFO, Thrissur. Dissemination of information on Champions Portal and the State Champion Control Room (SCCR) has been given to all MSME stakeholders through Webinars, WhatsApp, Facebook, Twitter and Email. The SCCR is working from 8 am to 8 pm everyday as per the roster decided by Joint Director & HOO. Quality Assessment Report (QA Report) is submitted every Monday after speaking with the grievant on a sample basis and after recording their feedback. Daily report is also being submitted by 5.30 pm every day. For FAQs we have created a template reply so that fast resolution may be provided. Once a champion grievance is received, the State Control room contacts both the complainant and the respondent and after understanding the scenario, we provide solution/guidance as the case may be. Further, a feedback register is being maintained and all queries received are contacted to assess the level of their satisfaction with respect to the solution provided.

Director, Directorate of Industries & Commerce, Government of Kerala has been made the nodal officer and his name is reflecting in the Champions portal as well. A dedicated WhatsApp group 'Champions-MSME-DFO-Kerala' has been created as per the instructions of Headquarters and there are Four Regional Champion WhatsApp groups all of which are actively functioning for further linkage.

Table 9.1: Status of Grievances received in the Champions Portal

	During 2023-24	Cumulative
Received Grievances	297	1092
Grievance resolved in 24 hours	130	613
Replied Grievance	297	1092
Pending Grievance	0	0

9.2. Assistance Provided through Enterprise Facilitation Cell

The Enterprise Facilitation Cell at MSME-DFO, Thrissur is facilitating the prospective and existing entrepreneurs for the development of MSME Sector. The number of persons who got assistance from Enterprise Facilitation Cell and through Officials of MSME-DFO, Thrissur during the year is as follows:

Table 9.2: Assistance Provided by MSME-DFO, Thrissur through Enterprise Facilitation Cell and Officers

Sl No.	Description	No. of units assisted
1.	Assistance given to prospective entrepreneurs	45816
2.	No. of existing entrepreneurs assisted	35997
Total assistance = (1) + (2)		81813

9.3. Central / Leather Workshop of MSME DFO, Thrissur

The following table shows the Revenue Earned

Workshop	No. of Job work done	Revenue Earned
Central Workshop	46	73,700
Leather Workshop		2,16,577
Total		2,90,277

9.4. Other Major Outreach Programmes of MSME-DFO, Thrissur

In addition to the targets and assignments from Office of Development Commissioner (MSME), MSME-DFO, Thrissur is actively involved in various programmes and has taken up initiatives of its own for the promotion of the MSME-Sector in the State. Most of these programmes were organised in association with various Central and State Government Departments, Industrial Associations, Academic Institutions, NGOs, etc. This section gives a bird's eye view of the activities carried out during the FY 2023-24.

- The Directorate General of Taxpayer Services (DGTS), Central Board of Indirect Taxes and Customs, Bengaluru Zonal Unit in association with (MSME)-DFO, Ministry of MSME, Govt. of India, Thrissur, Kerala, Federation of Indian Export Organisation (FIEO), Kerala, Confederation of Indian Industry (CII), Kerala, Association of Tax Practitioners (ATP), Kerala, Kerala Merchants Chamber of Commerce (KMCC), Kerala organized a webinar/Outreach Programme on the Topic "E-Invoicing in GST - in Malayalam Language" on 5th July, 2023. JD/HOO of MSME-DFO Thrissur delivered felicitation Address. The webinar had more than 400 participants.

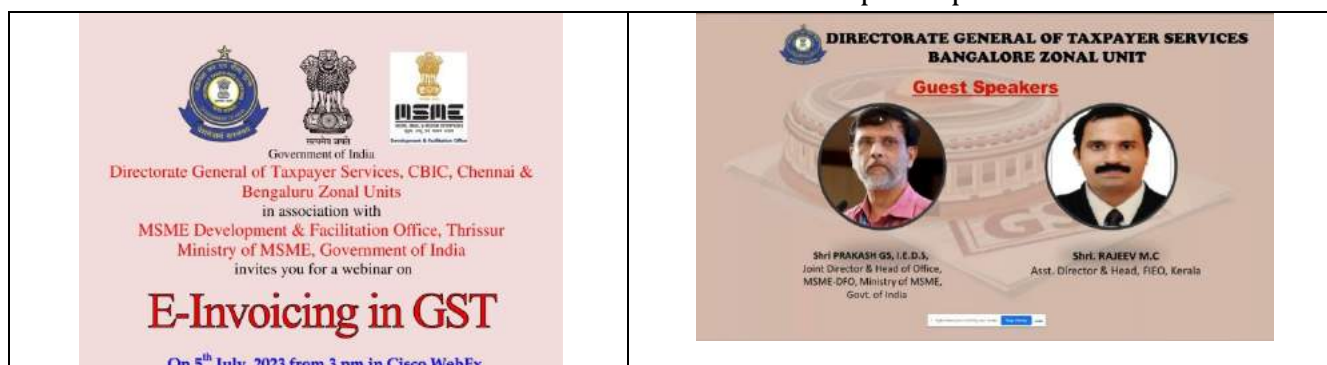

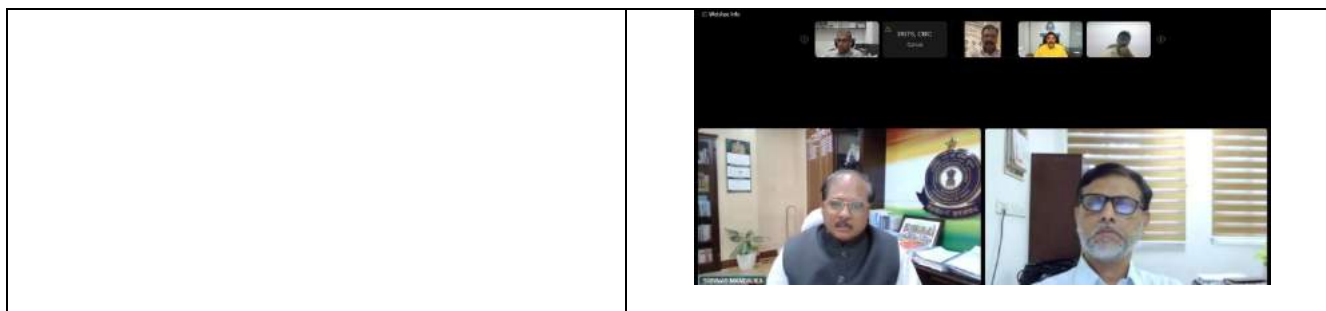

Flyer of Webinar on “E-invoicing in GST”/Snapshots from live Webinar

- Directorate General of Taxpayer Services, CBIC, Chennai & Bengaluru Zonal Units in association with MSME Development & Facilitation Office, Thrissur, Ministry of MSME, organized a webinar on Refund in GST on May 24th, 2023. Assistant Director(Statistics) Shri Vishesh Aggarwal delivered felicitation address on behalf of JD/HoO. The Webinar was attended by around 400 participants due to efforts of MSME DFO Thrissur by disseminating the information to all MSME Stakeholders in Kerala.

<p><i>Flyer for the Webinar</i></p>	<p><i>Screenshot of the Webinar Proceedings</i></p>

- Bank of India, Ernakulam Zone conducted credit outreach program in association with MSME Development and Facilitation Office, Thrissur on 24.07.2023 at MSME DFO, Thrissur’s Golden Jubilee hall. Shri Ajesh MS, Chief Manager Thrissur, Bank of India welcomed the Gathering. Shri G.S. Prakash, Joint Director & Head of Office, MSME DFO, Thrissur presided over the inaugural session. Shri PradeepRanjan Paul, Zonal Manager, Bank of India inaugurated the event. Shri Harpreet Singh, Chief Manager, Bank of India explained about the Small and Medium Enterprises loan schemes. Shri Anish Kumar, Zonal Marketing In-Charge spoke about Asset Backed Loan Scheme for Small Entrepreneurs. Smt Sarita J, Head of Agriculture Business Center, discussed about various Agri-Processing Schemes with Govt Incentives and Smt. Vidya talked about Doctor Plus scheme. Shri Vishesh Aggarwal, Assistant Director, MSME DFO, Thrissur explained about the various schemes of the Ministry of MSME, Government of

India. More than 90 prospective and existing entrepreneurs attended the event apart from Bankers/officials of Government Departments.

Flyer



Shri Pradeep Ranjan Paul, Zonal Manager, Bank of India inaugurating the Loan Mela

- The Evaluation meet of the clusters under One District One Idea (ODOI) initiative of Kerala Development and Innovation Strategic Council (K-DISC), Govt. of Kerala was conducted at MSME-DFO, Thrissur from 25.04.2023 to 28.04.2023. Stakeholders representing 39 clusters shortlisted under ODOI made presentation about the strategic innovation plan for the exponential growth of the clusters. The innovation based intervention plan of each cluster was prepared by an Education Institute selected by K-DISC. Representatives from 36 clusters and/or respective educational institutes made presentation about the growth proposal before a team of cluster & domain experts. The Evaluation exercise of the clusters is mainly coordinated by Shri Sivan Ambat, Senior Associate Faculty from Entrepreneurship Development Institute (EDI), Ahmedabad. Shri G S Prakash, Joint Director and Head of Office, MSME DFO, Thrissur, Shri Martin P Chacko Assistant Director, Shri P B Suresh Babu Assistant Director & CDO, Smt K.Rekha Investigator, joined the team of evaluators which included Additional Director of Industries, General Manager & Managers from DIC Thrissur, senior faculties from EDI Ahmedabad, KFRI, Kerala Agriculture University, etc. The strategic innovation plan of the following clusters, as prepared by the respective Institutes was presented during the four-day meeting.

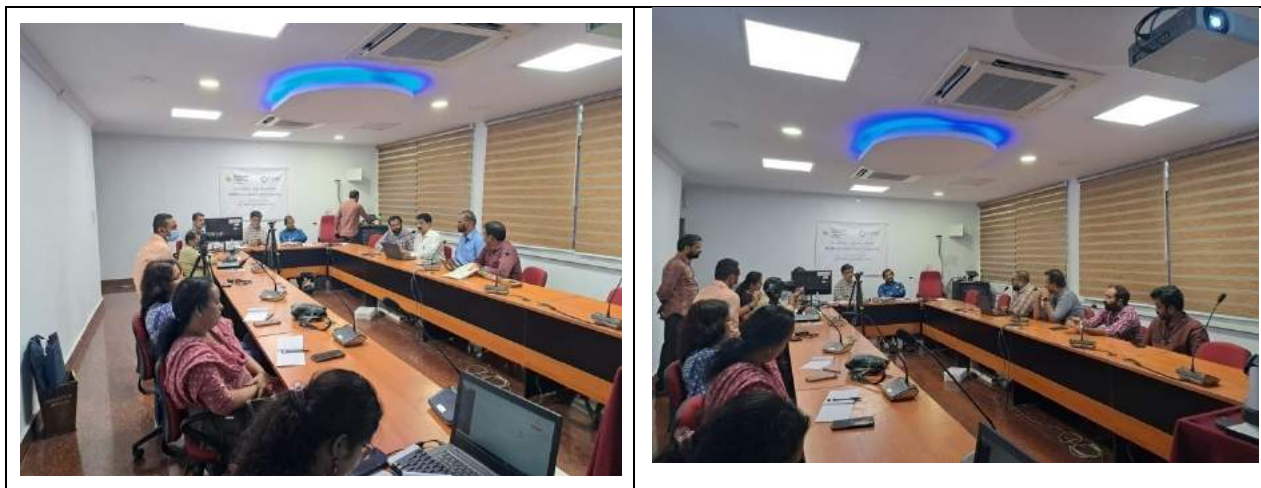

Photographs of evaluation meeting of clusters under ODOI conducted at MSME DFO Thrissur from 25.04.2023 to 28.04.2023

- On 29.12.2023 JD & HoO attended a meeting chaired by the Hon'ble Union Minister for State for Fertilisers and Chemical. Shri. Bhagwanth Khuba. Heads of departments and banks attended the meeting to review the progress of the implementation of GOI schemes as part of Viksit Bharat Yatra. During the discussion at the District Collectorate Thrissur, Hon'ble union Minister mainly focused on PM Vishwakarma scheme and enquired about the status of implementation. JD & HoO informed the Minister about the status, efforts and also about the awareness programme conducted/proposed. Further informed all bank regional heads about the scheme and sought their cooperation to implement the scheme effectively.



Hon'ble Union Minister during the meeting



JD & HoO addressing the participants

- JD & HoO had meetings with Shri M G Rajamanickam IAS, LSGD-Principal Director, Thiruvananthapuram, Shri Suman Billa IAS, Principal Secretary Industries, Government of Kerala, Smt. Tinku Biswal IAS, Principal Secretary Revenue, Govt of Kerala and Managing Director of Kerala Artisans Development Corporation regarding various issues related to implementation of PM Vishwakarma Scheme on 24.11.2023.
- Joint Director & HoO attended and presided over the valedictory function of the First

batch of training of PM Vishwakarma beneficiaries at JSS Palakkad Headquarters Theradapuzha Building, Palakkad on 03.02.2024. Regional Director of RD MSDE, GM DIC Palakkad, LDM Palakkad, AD LSGD, Chairman & Director of JSS, CSC District Manager etc addressed the beneficiaries. One batch of beneficiaries on tailoring completed their training and another batch of training for barber trade were in progress and one more batch in tailoring commenced on 03.02.2024 at the JSS centre Palakkad. The beneficiaries expressed their happiness and rated the training as "very useful" to them. Training also covered areas on business development.



JD & HoO addressing the participants during the programme

- Joint Director & HoO attended the Investors Meeting at Hotel Garuda on 22.02.2024. JD & HoO handed over a copy of the PM Vishwakarma guidelines to Shri K Rajan, Hon'ble Revenue Minister, Government of Kerala and explained the scheme in brief



JD & HoO during the Investors Meet

- MSME-DFO convened an online State Level Screening Committee meeting on PM Vishwakarma on 14.03.2024 UT of Lakshadweep to discuss the Scheme in Detail and to clarify the queries of the implementing departments. Officers of Industries Department UT of Lakshadweep and other implementing departments attended the meeting. MSDE & SLBC also attended the meeting. Cleared 12011 applications after stage 3 verification.

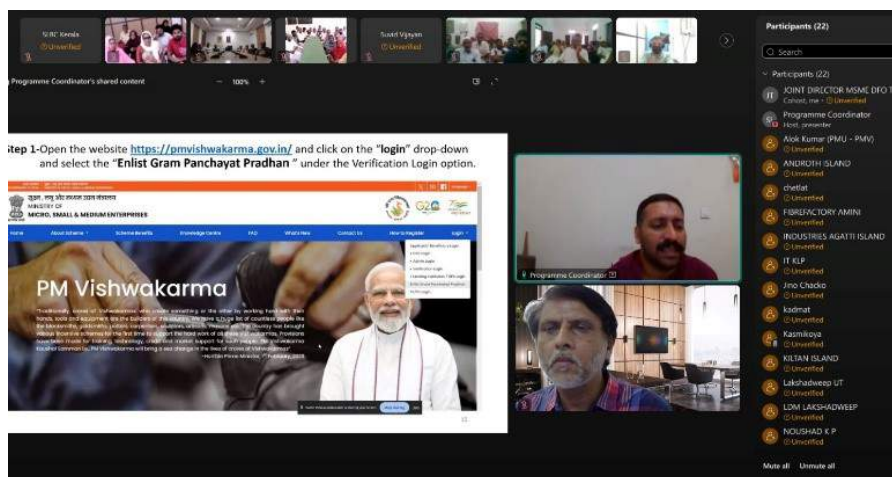

From the Online Meeting

- Lachithamol U.C., AD(EI) participated and talked about the support from Ministry of MSME for Women Entrepreneurs in the panel discussion on the topic "Entrepreneurial Development and Convergence of Schemes" organised by Kudumbhasree Mission as a part of Micro Enterprise Conclave at Ernakulam on 23.04.2023 which was attended by about 1500 delegates.



- As the part of R&D Institute & Cluster interaction, MSME DFO Thrissur organized a virtual meet on 16.5.2023 between CSIR-CMERI & Agriculture Implements Cluster, Shornur in which 7 senior scientists from CSIR - CMERI, Durgapur , West Bengal, cluster representatives, their local mentor institutes (Jawahar college of Tech.& management Ottapalam, and Govt. Engg. College, Palakkad), Joint Director & HoO, AD (Food), AD& CDO, other officials from MSME DFO Thrissur participated. The meeting discussed about possible tie up between Agri implement cluster and CSIR-CMERI, Durgapur as Agriculture Implement Cluster Shoranur, a traditional cluster in Palakkad District, with about 120 micro units engaged in manufacturing various agriculture implements have been facing difficulties in product diversification & technology up gradation. The principal scientists from CSRI- CMERI presented further scope of collaboration after listening to the presentations made by the DFO, Mentor Institutes and cluster members. Joint Director forwarded the minutes of the meeting to the Director, CSIR-CMERI and further discussed with the senior scientists. MSME DFO Thrissur requested Director CSIR-CMERI to depute suitable technical officers from

CMERI to visit the cluster for the on the spot assessment and further engagement. Response from CMERI-CSIR is awaited.

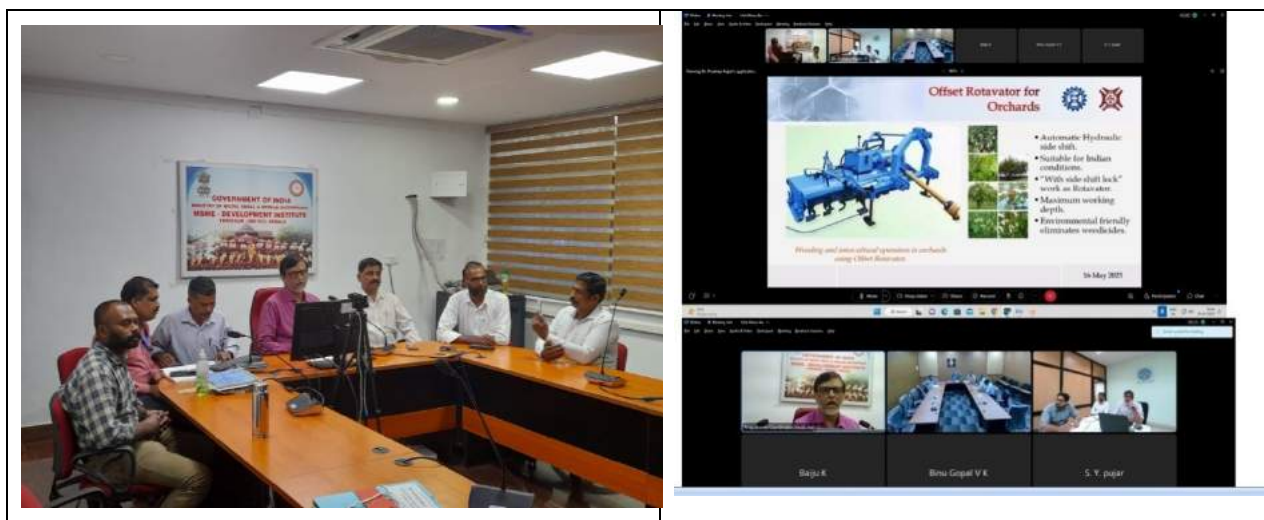

As the part of R&D Institute & Cluster interaction, MSME DFO Thrissur organized a virtual meet on 16.5.2023 between CSIR–CMERI & Agriculture Implements Cluster, Shornur

- MSME DFO, Thrissur organized a webinar in association with GS1 India, on the topic “Barcode for Products” on 17.05.2023 at 3 pm to create awareness on: Increasing supply chain security & efficiency through Barcode; Increasing visibility in retail, e-commerce and export; GS1 Barcode Registration Procedures; Reimbursement of expenditure incurred by Micro Enterprises for obtaining barcode from Ministry of MSME, Government of India. The webinar was inaugurated by Shri. G.S.Prakash, IEDS, Joint Director & HoO. Ms. Seethal K., Business Development Officer of GS1 India, Southern Region talked about Importance/Benefits of Barcode and GS1 Barcode Registration Procedures. Smt. Lachithamol U.C., AD (EI) & Programme Coordinator briefed about the Barcode Expenditure Reimbursement Scheme of O/o DC (MSME). 56 participants attended the webinar and interacted with the faculties to clear their doubts.

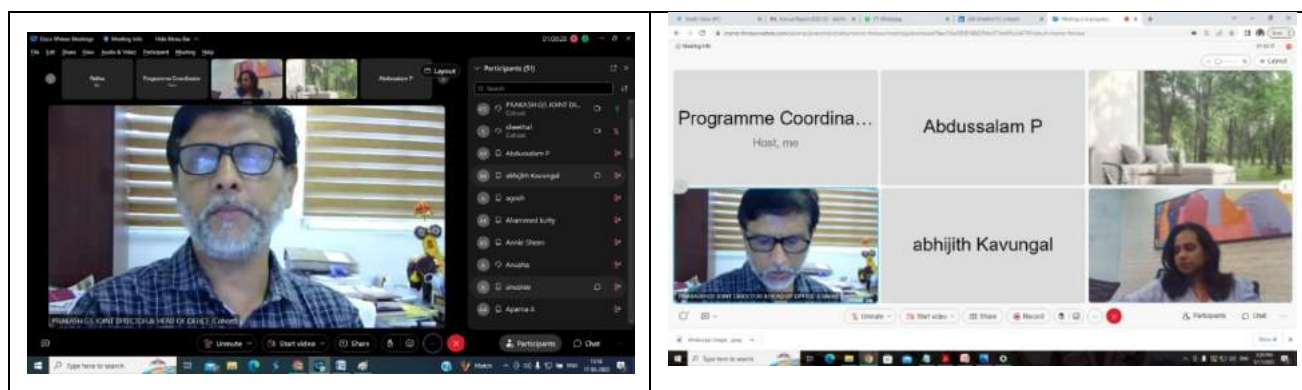

- During the DFOs meeting held on 02/5/2023 at Conference Room, DPIIT, Udyog Bhawan, New Delhi, it was suggested by Secretary [MSME] & AS & DC [MSME] that there is a lack of interaction and sharing of ideas between different Verticals of Ministry of MSME and Secretary [MSME] & AS & DC suggested that all the Verticals of

Ministry of MSME at the Regional level should interact with each other on a regular basis to share new Schemes/Ideas/Issues faced/etc. In the light of the above, MSME DFO Thrissur convened an online meeting on 11.05.2023 among the different verticals of Ministry of MSME based in Kerala. The meeting was inaugurated by Shri. D. Kuppuramu, Chairman, Coir Board & Joint Director & Head of Office, MSME DFO, Thrissur delivered Presidential Address, In charges /Officers from Coir board, KVIC, NSIC, SIDBI, Technology Centre Kochi, PPDC, Agra participated in the programme. Presentations on different Schemes handled by each vertical/new changes/issues etc. were made. MSME DFO, Thrissur also created a WhatsApp group for the exchange of information between various verticals under the Ministry of MSME. Chairman Coir board invited all others for the next physical meeting at Coir Board, Kochi.



Shri G. S. Prakash, IEDS, Joint Director & Head of Office, MSME DFO, Thrissur delivered Presidential Address



Shri. D. Kuppuramu, Chairman, Coir Board delivered the Inaugural Address

- AD & CDO attended a workshop on rubber molded products at Hotel AIDA, Kottayam

organized by KRL and Rubber Board. He took a Session on MSE CDP and other Schemes of DC (MSME). More than 50 participants attended the meeting held on 23.06.2023. Group Discussion and a session on clearing of Doubts of participants were included in the meeting. Smt. Sheela Thomas, IAS (Rtd), Chairperson and Managing Director of KRL chaired the meeting. Eminent speakers from various sectors attended the meeting.



- Assistant Director (Statistics) attended and spoke of Ministry of MSME support for entrepreneurs at Loan Mela organized by SBI RO Thrissur at Jawahar Bala Bhawan Hall, Thrissur on 14.06.2023. MSME-DFO, Thrissur gave ample publicity for the event which witnessed a footfall of more than 400 MSME units.



Newspaper Article of Loan Mela

- MSME-DFO Thrissur organized awareness programme on Government e-Marketplace and Vivad se Vishvas I Scheme in association with Kerala State Small Industries Association (KSSIA) at MSME-DFO, Thrissur on 15.06.2023. Sessions were handled by Shri A V Muralidharan, Deputy CEO, O/o Government E Marketplace, New Delhi, Shri Manesh Mohan, State Business Facilitator of GeM and Assistant Director, MSME-DFO, Thrissur. 82 prospective and existing entrepreneurs attended the awareness programme.



JD & HoO addressing the participants

Shri A V Muralidharan, Dy CEO, GeM addressing the participants

Participants

- An awareness programme on GeM was also organized at Kalamassery, Kochi, Ernakulam on 15.06.2023 in association with Kerala State Small industries Association, Ernakulam district unit. Sessions were handled by Shri A V Muralidharan, Deputy CEO, O/o Government E Marketplace, New Delhi, Shri Manesh Mohan, State Business Facilitator of GeM. 73 prospective and existing entrepreneurs attended the awareness programme.



View of participants awareness programme on GeM in Ernakulam

- MSME Development and Facilitation Office, Thrissur celebrated International MSME Day 2023 in association with SCMS Cochin School of Business, National Small Industries Corporation (NSIC) & Small Industries Development Bank of India (SIDBI) at SCMS Cochin School of Business. The celebration was inaugurated by Shri P. Rajeeve, Hon'ble Minister for Law, Industries & Coir, Govt. of Kerala. Shri Prakash G.S.,

Joint Director & Head of Office, MSME-DFO, Thrissur gave the theme presentation and welcomed the gathering. Dr Radha P. Thevannoor, Group Director, SCMS delivered presidential address. Shri M. Sreevatsan, Zonal GM, NSIC & Shri K. V. Karthikeyan, DGM, SIDBI, Shri. Rakesh V.R., GM in Charge, DIC, Ernakulam delivered special addresses.



Shri P. Rajeev, Hon'ble Minister for Law, Industries & Coir, Govt. of Kerala inaugurating the National Workshop

- Centre for Development of Advanced Computing (CDAC), Bangalore (a premier R&D organization for Research and Development in IT, under the Ministry of Electronics and Information Technology, Government of India) in association with MSME-DFO, Thrissur organized a virtual mode workshop on 15.06.2023 in order to create awareness about PARAM Utkarsh facility information among the Industries/MSME/Startups/Entrepreneurs. Joint Director & HoO, MSME-DFO, Thrissur inaugurated the virtual workshop. The workshop was attended by 80 MSMEs.

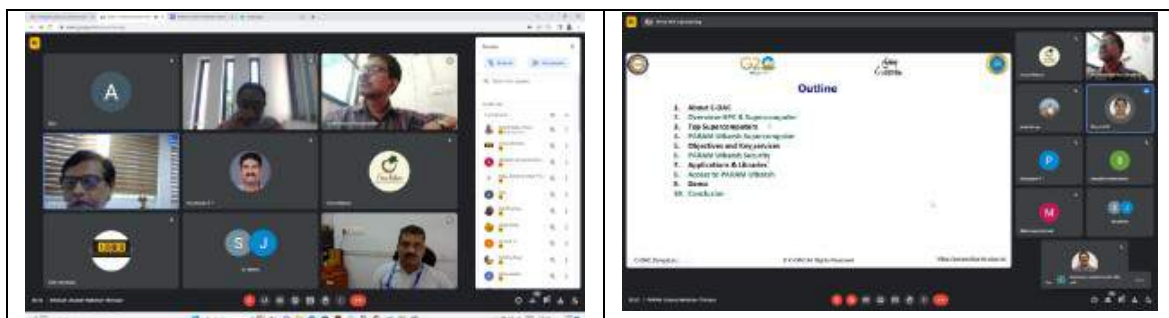

Shri. G.S. Prakash, JD & HoO, MSME-DFO, Thrissur inaugurated the Webinar on PARAM Utkarsh, Conducted virtually on 15.06.2023. Smt. Vidya M.G. Scientist C-DAC took the session.

- Assistant Director (Chemical) Smt.Rekha.K delivered a session on MSME ZED Certification Scheme & Lean during the inaugural function of KIED Flagship training programs ON 10/10/23 at KIED Campus, Kalamasserry. Hon'ble Minister of Industries, Coir & Law, Shri.P.Rajeev inaugurated the programme and Smt.Seema Kannan, Municipal Chair person presided over the function. Approximately 120 participants attended the session.



- Smt.Rekha.K, Assistant Director delivered a session on ZED certification and other schemes of M/o MSME at Water Expo
- Smt.Rekha.K, Assistant Director delivering Session on MSME ZED Certification Scheme at EDC Tower1, Inkel Business Park, Angamaly organized by KIED on 23rd August 2023. 50 MSME manufacturers attended the programme.



- Joint Director & HoO on 03.12.2023 visited the exhibition of 5th Global Ayurveda Festival, Kerala 2023 at Greenfield Stadium, Thiruvananthapuram. He handled the session on programmes and policies of Ministry of MSME during the fest. The meeting was held with the members of Ayurveda Hospital Management Association. Hon'ble Vice president of India inaugurated the Global Ayurveda Fest (GAF) at Thiruvananthapuram. M/o MSME provided assistance for 88 MSE stalls under the DTF component of PMS scheme of DC-MSME, addressed the participants of Global B2B meet session and explained the programmes & policies of M/o MSME, Government of India.



Photographs from Global Ayurveda Fest 2023

- JD & HoO attended State level meeting and exhibition of Association of Automobile workshops in Kerala at Thrissur on 15.12.2023 and inaugurated the seminar.



- Joint Director & HoO had an interactive meeting with office bearers of Jaggery Manufacturers Association at Marayoor on 06.04.2023 at their office. During the meeting, he informed association/cluster members about the various aspects to apply under MSE-CDP and about other promotional schemes of Ministry of MSME, GoI. During the interaction, Cluster members requested for technical support and value added products from Cane Juice & Jaggery and they were linked the with Associate Director who is retired from Defense Laboratory, Mysore and interaction was arranged between Technical Expert and Cluster Members. He also visited a few Jaggery manufacturing units in Marayoor & Kanthalloor on 07.04.2023 and had interaction with Food Products processing manufacturers from various parts of Idukki district and also visited GI Products marketing shops arranged by association members and informed them about the reimbursement schemes for the GI and also marketing support under PMS Scheme.



JD & HoO during the interaction with the association/cluster members



A shop to sell exclusively GI products in Marayoor established by Jaggery manufacturer's Association

- Joint Director & HoO attended and delivered Key Note address during the National Vishwakarma Seminar on 08.10.2023 organized by National Vishwakarma Federation at Vishwa Karma Bhavan, Thrissur. JD & HoO explained the PM Vishwakarma scheme in detail and answered many queries.



JD & HoO handling the session on PM Vishwakarma during the seminar

- On 05.11.2023 Joint Director & HoO had a meeting with Vishwakarma group leaders, Thiruvananthapuram Corporation Councilors, CSC District Co-ordinators & NGOs and discussed about PM Vishwakarma scheme implementation and creating awareness about the scheme through ESDP programmes.



JD & HoO interacting during the meeting with Vishwakarma Group leaders, Thiruvananthapuram Corpn Councilors, CSC District Co-ordinators & NGOs

- Lachithamol U.C., AD(EI) participated in the inauguration function of Fifex 2023 at Angamaly on 06.05.2023 and visited the stalls. In the felicitation address, AD(EI) briefed about the PMS Scheme of the Ministry of MSME.



- AD & CDO attended a workshop Organized by EMAT - Event Management Association Thrissur on 26.06.2023 at Hotel Hyatt Regency Thrissur and described briefly about the Schemes of MSME General and about MSE-CDP and GeM Portal in details. Around 50 members attended the meeting. A session on clearing of doubts of participants was included in the meeting.



- Assistant Director (Statistics) Shri Vishesh Aggarwal handled a session on M/o MSME Schemes and its benefit at a B2B conclave organized by the Hindu Economic Forum held on 18th June 2023- Sunday 12 PM at Asoka Inn, Sakthan Nagar, Thrissur. More than 150 exiting entrepreneurs attended the session.



- A conclave on MSME@EMAT was organized at MSME-DFO, Thrissur on 20.07.2023 as per the request received from the President Event Management Association Thrissur (EMAT). The Programme was organized with the purpose to gain insights into the MSME schemes offered by M/o MSME, Government of India. 65 association members participated in the programme. Officers from MSME-DFO, Thrissur handled the sessions by disseminating various schemes to the participants through Power point presentations.
- Joint Director & HoO attended the Jewellery Manufacturers Association meeting on 19.09.2023 at Thrissur. During the meeting JD & HoO informed the members of the association about various programmes and policies of Ministry of MSME, Government of India.



JD & HoO during his address



Participants for the programme

- Joint Director & HoO attended the 47th District meeting of KSSIA at Hotel Dass Continental, Thrissur on 25.09.2023. During the function Hon'ble Minister honored MSMEs with ZED certification from Thrissur District.



During the inaugural function

- Assistant Director(Statistics) Shri Vishesh Aggarwal handled session on Ministry of MSME Scheme & Policies and Entrepreneur Motivation at the State Conclave of Cement Bricks and Interlock Manufacturers Association held at Chalakudy on 7th March, 2024.



- Assistant Director(Statistics) Shri Vishesh Aggarwal handled session on Ministry of MSME Scheme & Policies and Entrepreneur Motivation at the State Conclave of HEF Kerala held at Gokulam Park Hotel, Ernakulam on 23rd March, 2024.
- Joint Director & HoO inaugurated the district training programme by the Secretary of the Forum of Registered CSC Entrepreneurs (FORCE) on 17.03.2024.



- An awareness programme was organized in association with Universal Engineering College, Vallivattom, Irinjalakuda, Thrissur on 26.04.2023 in which a Session on MSME Schemes was taken by Smt.Rekha.K, Assistant Director, MSME-DFO, Thrissur. 54 participants were there.



- A team of Officers from MSME-DFO, Thrissur visited Amrita Viswa Vidya Peetham, Kollam based on their application for setting up an IPFC under MSME Innovative Scheme. The officials interacted with Dr.Krishnashree, Dean, Amrita University and other officials regarding the IPFC, Innovative Scheme and with Ammachi Labs regarding the training programmes under SANKALP Scheme. The applications were recommended and forwarded to PMAC by this office on 10th May 2023. On 05th January 2024 the centre was approved in-principle by Office of Development Commissioner (MSME), New Delhi.



Meeting with officials of Amrita IPFC

- Joint Director & HoO inaugurated State Level Entrepreneurship Summit 2023 (VISTLE) on 03.06.2023 organised by Innovation and Entrepreneurship Development Centre (IEDC), Vidya Academy of Science and Technology, Thrissur. During the two-day conclave, 200 plus Start ups and aspiring entrepreneurs from various Engineering Colleges participated in the programme. The summit was organized to promote campus entrepreneurship in the State. JD & HoO, made a presentation on the programmes and policies of M/o MSME, Government of India for the beneficial of the participants.



JD & HoO inaugurating the conclave



Participants

- Joint Director & HoO attended & addressed during the valedictory function of one week Environment Week Celebration organized by ESAF Small Bank at their Headquarter, Mannuthy on 16.06.2023. CEO Kochi, Water Metro, Managing Director & CEO ESAF Bank and other Senior Officers and Branch Managers attended the function. The branches which performed best Environmental protection activities were honored during the programme.



JD & HoO inaugurating and addressing the participants during the valedictory function



Participants

- Investigator Chemical delivered a session on MSME Schemes to Women Entrepreneurs of ESAF foundation as a part of International MSME day. 50 participants attended the programme.



- Investigator Chemical delivered a session on Schemes and Policies of Ministry of

MSME, Govt of India at KILA Campus today for the programme organized by NGO Parivaar Kerala. The programme was inaugurated by Dr.Joy Elamon, Director, KILA. The NGO is an association of parents of children with Intellectual and Developmental Disabilities (autism, cerebral palsy, intellectual disability and multiple disabilities). Approximately 60 participants from all part of Kerala attended the session.



Session at KILA

- Meeting with representatives of MSMEs and officials from Kottayam Dist by Assistant Director(Food) Shri Martin P Chacko and AD & CDO was held on 13.07.2023. Dr. Radhakrishnan E K, M G University, Kottayam, Prof. Dr.K J Kurian, M G University, Kottayam, Smt, Joy John, Smt. Elizabeth Farm Tourism Entrepreneurs, 12 members attended the meeting.



Meeting with representatives of MSMEs and officials from Kottayam Dist by AD Food and AD & CDO held on 13.07.2023.

- Joint Director & HoO was invited as resource person for MSME programme 'Innovate UP 2k23' by the Commerce Department, Vimala College, Thrissur. JD & HoO handled a session on 'procedure to commence an enterprise and maximization and utilization of capital'. Products manufactured by the students were exhibited during the programme.



Photos from the function

- Joint Director & HoO attended and inaugurated the Viksit Sankalp Yatra organized at Tholur Panchayat, Thrissur on 22.12.23.



JD & HoO inaugurating the programme and during his inaugural address

- Joint Director & HoO attended a panel discussion as part of Kerala Technology Expo (KTX)" conducted from 29th Feb to 2 March, 2024 at Calicut Trade Centre. KTX is an

annual technology expo envisaged as the congregation of a number of industry verticals and horizontals aligned to the key emerging trends relevant to the Malabar region. The Topic of discussion was "Tech support for MSMEs". Other panel members were Mr Rasak, MD VKC, Damodar Avanoor, past state President KSSIA, Riyas, Director Kerala knowledge Mission. Mr Roshan, Editor Mathrubhumi was the moderator. More than 200 participants attended the discussion.



Photographs of the panel discussion

Chapter 10

Establishment, Capital Expenditure and Budget

10.1. Major Activities Carried Out during the FY

The Establishment and Accounts (Budget) Division of the MSME –DFO, Thrissur typically handles various administrative and financial tasks to support the development and growth of MSMEs in the region.

10.2. Capital Expenditure

During the FY2023-24, a lot of infrastructure up gradation activities were taken up by the establishment section with the help of CPWD. This office was facing acute shortage of water in the months from February to May, even for meeting essentials needs. As a solution to this, on our request, O/o DC-MSME sanctioned Rs 2699900 towards construction of MS overhead tank of 10,000 litre capacity, including drilling of bore well and providing water supply line from bore well to tank. The work was completed.

Further sanction of Rs 416000/- was accorded for construction of wash area and necessary work to avoid water seepage to dining hall during the rainy season. The work in this regard was completed by December 2023 and it was made possible to use the wash area during the various programs conducted at our office.

CPWD Electrical Division was also sanctioned funds for maintenance of electrical installations to the tune of Rs 1590524. The details of funds sanction and utilization is given below:-

Sr. No.	Details of the Work	Amount Sanction (in Rs.)	CPWD Division to which fund was transferred	Expenditure (in Rs.)	Percentage Expenditure (%)
1	MOEI and Fans A/c repair maintenance and operation of 100kva dg set, 1 No 13 passenger lift water supply pump sets etc at MSME Pullazi Thrissur during 2023-24 PE VIDE letter no D.11011/2/2022-23/Estt dated 12-04-2023	15,90,524	Electrical Division	15,04,912	94.6%
2	For providing wash area for dining hall, seating gap for arresting water leakage etc. at MSME DFO Thrissur VIDE letter no D.11011/2/2022-23/Estt dated 26-04-2023	4,16,000	Civil Division	31,15,594	99.9%
3	Construction of 1 no of MS overhead tank 10000 litre capacity 11.00m staging and drilling of 6' dia bore well and providing CPVC Water supply line from bore well to	26,99,900			

tank from MSME DFO Thrissur PE VIDE
letter no D.11011/2/2022-23/Est. dated
01-05-2023

10.3. Budget Allocation and Expenditure under Various Heads

• PLAN FUND

SCHEME	HEAD	SANCTION DETAILS	SAN. AMT	EXPENDITURE	BALANCE
DTE-ESDP	98.01.11	SD-20016/2/2023-24-DCMSME-ESDP-(D-09) dt. 28.08.23 & 06.12.23& 14.02.2024	5,20,000	519963	37
PMS - 1	97.02.33	5(5)/2020-21/MS/EC/Pt.III dt. 18.05.2023 Balance surrendered	9,97,808	671559	3,26,249
CLUSTER DTE	99.05.11	1(699)/CDD/CDO/2017 dt. 18.04.2023	1,00,000	99501	499
CLUSTER OE	99.05.13	1(699)/CDD/CDO/2017 dt. 18.04.2023 & 22.12.2023	2,50,000	249995	5
Library	4851.00.102.33.00.7 7	1(19)/2022-2023-Library dt. 05.06.2023	50,000	49794	206
PMS-Bar code-Ist	97.02.33	5(5)/2020-21/MS/EC/Pt.II dt. 01.06.2023	42,680	42680	0
DTE-Training	285100001.05.01.1 1	A-52/1/2022-HR dt. 01.05.2023, 02.06.2023 & 30.10.2023, 14.03.2024	2,50,761	250761	0
CPWD-Civil & Electric-Minor works	285100001.05.01.2 7	64(02)/D1/Minor-works/2022-23/04 dt. 22.04.2022 & 16.01.24	47,06,424	4620506	85918
IPR(Trademark/Patent)	95.04.13	TY-26015/1/2022-IPR -DCMSME dt. 19.06.2023 Balance surrendered	17,80,000	955336	8,24,664
PMS-2nd	97.02.33	5(5)/2023-24/PMS/EC dt. 03.07.2023, Balance surrendered	3261170	2789168	4,72,002
RAMP	99.11.33	5(5)/2023-24/PMS/EC dt. 03.07.2023	60,400	50407	9,993
RAMP-IT infra	99.09.13	L/AFI/RAMP/INFRA/2023 dt. 27.06.2023 Balance surrendered	3,18,840	306677	12,163
PMS-VDP /National workshop/Seminar	97.02.13	5(5)/2020-21/MS/EC/Pt.II dt. 20.07.2023	25,00,000	2488698	11,302
SENET-WEB MAINT& Internet	28510.0001.05.01.2 8	SNT/2/23-EE dt. 01.08.2023 dt. 01.08.2023	50,000	49988	12
SENET-AMC	28510.0001.05.01.2 8	71(3)/MSME-Dis/SENET/202-23 dt. 30.06.2022	1,25,000	125000	0
SENET - CONTING	28510.0001.05.01.1 9	71(3)/MSME-Dis/SENET/202-23 dt. 30.06.2022	40,000	39938	62
TE-GEN ESDP/EAP/M DP	98.01.09	SD-20016/4/2023-24-DCMSME-ESDP-(D-09)-4603 dt. 09.08.2023	31,75,000	3161760	13240
TE-TASP ESDP/EAP/M DP	796.65.01.09	SD-20016/4/2023-24-DCMSME-ESDP-(D-09)-4606 dt. 09.08.2023 Balance surrendered	2,15,000	164974	50,026
TE-SCSP ESDP/EAP/M DP	789.66.01.09	SD-20016/4/2023-24-DCMSME-ESDP-(D-09)-4605 dt. 09.08.2023	5,80,000	576753	3247
LEAN	99.09.13	17/MSMECompetitive-Lean/PMAC/2022Part(II) dt 2/11/2023	5,60,000	542292	17,708

Balance surrendered					
PM Viswakarma	285100102.03.12.26	No.S-15/12/2023-I&F dt. 08.12.2023 & 24.01.24 Balance surrendered	48,70,000	3841859	10,28,141
PMS-Barcode - 3rd	97.02.33	5(5)/2020-21/MS/EC/Pt-II dt. 16.01.2024	2,22,640	222640	0
Hackathon3.0 (women)	95.04.28	F.No.6(26)/Inc/Constitution of DESC-Hackathon 3.0 dt. 17.1.24	1,24,600	124600	0
PMS-Feb-Exhibition	97.02.33	5(5)/2020-21/MS/EC/Pt.II dt. 06.02.2024 & 04.03.24, Balance surrendered	73,14,720	6664722	6,49,998
PMS-Barode - March	97.02.33	5(5)/2020-21/MS/EC/Pt-II dt. 08.03.2024	3,32,440	332440	0

- NON PLAN**

Subject	Subhead	Sanction details	San. Amt	exp	balance
Salary & Allowances	285100001.05.01.01 285100001.05.01.07	G.20011/1/2023-B&A/1-50 dt. 06.04.2023 & 04.08.2023 & 04.12.2023 & 19.02.24	3,82,01,874	37251645	9,50,229
Medical	285100001.05.01.06	G.20011/1/2023-B&A/1-50 dt. 06.04.2023 & 606-620 dt. 11.12.23	79,000	65306	13,694
LTC	285100001.05.01.08	G.20011/1/2023-B&A/ 606-620 dt. 11.12.23	1,00,000	113	99,887
OE	285100001.05.01.13	G.20011/1/2023-B&A/1-50 dt. 06.04.2023 & B&A/319-366 dt. 24.08.2023 & B&A/525/549 dt. 9.11.23 & 632-660 dt 18.1.24	36,69,000	3669000	0
Digital Equipment	285100001.05.01.19	G.20011/1/2023-B&A/1-50 & 606-620 dt. 11.12.23 dt. 06.04.2023	68,000	68000	0
Fuel & Lubricants	285100001.05.01.24	G.20011/1/2023-B&A/1-50 dt. 06.04.2023, 467-517 dt. 11.10.23	60,000	59892	108
Repair & Maintenance	285100001.05.01.29	G.20011/1/2023-B&A/1-50 dt. 06.04.2023 and 71-117 dt. 22.05.2023 & 606-620 dt. 11.12.23	1,37,000	137000	0
DTE	285100001.05.01.11	G.20011/1/2023-B&A/1-50 dt. 06.04.23 & B&A/289-318 dt. 10.08.23 & B&A/387-421 dt. 13.09.23 & B&A/525-549 dt. 9.11.23 & 606-620 dt. 11.12.23 & 27.03.24	6,34,000	634000	0
RRT	285100001.05.01.14	G.20011/1/2023-B&A/51-69 dt. 25.04.2023 & 606-620 dt. 11.12.23	40,000	37968	2,032
Prof. Service	285100001.05.01.28	G.20011/1/2023-B&A/51-69 dt. 25.04.2023, Surrendered-4,44,000	7,50,000	304704	4,45,296
SAP	285100001.05.96.13	G.20011/1/2023-B&A/319-366 dt. 24.08.2023 & B&A/430-466 dt. 4.10.23	55,000	55000	0
ORE	285100001.05.01.49	G.20011/1/2023-B&A/319-366 dt. 24.08.2023 & B&A/525-549 dt. 9.11.23	46,000	43730	2,270
Rewards	285100001.05.01.05	G.20011/1/2023-B&A/467-517 dt. 11.10.2023	2,12,000	197007	14,993
Artisans DTE	285100.102.03.12.11	D-64/DFO/RDC/23-24(e-4026098) dt. 18.01.2024	2,25,000	225000	0
Artisans OE	285100.102.03.12.13	D-64/DFO/RDC/23-24(e-4026098) dt. 18.01.2024	52,000	51062	938

A total of 2576 bills were passed in the FY 23-24 amounting to Rs.6,84,34,287, out of which Rs3,27,90,875 was specifically pertaining to PLAN schemes. Apart from this an amount of Rs47,06,424 was authorised to CPWD for minor works.

Out of the total procurement of Rs45,52,711/- done by this office in FY 23-24, Rs 37,12,405/- worth procurement was made through GEM.

10.4. Brief report & Photos on activities under 'Swachhta' Action Plan (SAP)

10.4.1. Rain Harvesting Project completed under aegis of SAP

Towards preserving and ensuring rain water for future use, rain water harvesting project was taken up in MSME-DFO, Thrissur under the Swatchatha Action Plan in the previous financial year itself. But due to unavailability of funds, the project could be completed only this year. This financial year, soak pits were constructed and pipes were laid from water tank to these soak pits. Though endowed with heavy rain from June to August, water is scarce during the summer month from February to May.

This project will contribute to recharging groundwater aquifers, which is crucial for maintaining water security in the region and this has been done through soak pits dug in the front garden; the garden near car parking. Total roof area where rain harvesting system is installed is 1564 sq meter.





As per experts in the area of rain harvesting, roughly, 1 mm of rain over 1 square metre of roof equals 1 litre of water. Therefore our projects helps in conserving approximately 68816 litres of water (Total annual rainfall/day in Kerala is taken as 480cm and it is assumed that rainfall in this range happens almost 120days of the year in the region)

10.3.2. One day Workshop on “E-waste Management and Business Opportunities” organized as part of World Environment Day

On the occasion of World Environmental Day, under the aegis of Mission LiFE and Swatch Bharath Abhiyan, MSME-DFO, Thrissur, M/o MSME, Govt. of India in association with C-MET (Centre for Materials for Electronics Technology), Hyderabad under the Ministry of Electronics and Information Technology (MeitY), Govt of India organized one day workshop on " E-waste Management and Business Opportunities " .

Electronic waste, or e-waste, is a growing environmental problem that results from the improper disposal of electronic devices. These devices contain hazardous materials, such as lead, mercury, and cadmium, which can pollute the environment and pose a risk to human health. Electronic devices also contain valuable materials, such as gold, silver, and copper, which can be recycled and reused in the production of new devices. By recycling e-waste, we can conserve our natural resources and also create jobs and stimulate local economies. With the idea of reducing E-waste, while ensuring the proper disposal and recycling of the same and further educating the stakeholder community of various oppurtunities the sector has to offer, the workshop on “E-waste Management and Business Opportunities” was organized on 05.06.2023



Shri. V.R. Krishna Teja IAS, District Collector, Thrissur inaugurated the workshop and Shri.G.S.Prakash, Joint Director presided over the function



Participants attending the workshop and undergoing dismantling and segregation training conducted as part of the programme

C-MET has now informed that as a result of the workshop and subsequent actions, C-MET is now working with Govt. of Kerala for establishing E-Waste dismantling and recycling facilities at three different locations in the State of Kerala.

10.3.3. Fit India Freedom Run

Fit India Freedom Run with the theme **Swachh Bharat Swasth Bharat** was taken up with lot of enthusiasm and fervour by officials of MSME-DFO, Thrissur. This time around Fit India Mission converges with Swachh Bharat Abhiyan with Fit India Freedom Run where fitness meets Swachhata. Efforts were taken by officials to clean the premises of MSME-DFO, Thrissur and cleaning the neighbourhood along with fun filled exercises under the leadership of Shri Prakash G.S., JD&HoO.



10.4. Brief Report on the various activities taken up by Establishment Section

- As instructed by O/o DC (MSME), MSME-DFO, Thrissur organized 9th International Yoga Day celebrations from 19.06.2023 to 21.06.2023 in association with Heart fullness Institute, Thrissur Chapter which is recognized by Ministry of Culture and National Ayush Mission, Kerala. The programme was inaugurated by Shri G.S. Prakash, Joint Director and HoO, MSME-DFO, Thrissur. In a span of three days i.e from 19.06.2023 to 21.06.2023, trainers from Heartfulness Institute under the guidance of Shri T.P.Narayanan explained in details & conducted sessions on yoga, pranayaam and meditation with an aim to bring out the hidden potential in all.



Photographs of the Yoga Day celebrations

- As a part of Independence Day celebrations, Joint Director & HoO hoisted the National Flag at MSME-DFO, Thrissur on 15th August, 2023. Officers and staff attended the National Flag hoisting ceremony.

- As instructed by O/o DCMSME, MSME-DFO, Thrissur has actively participated and publicized the mega Program namely **Meri Maati Mera Desh** with the tagline '**MITTI KO NAMAN, VEERON KA VANDAN**' on 15.08.2023. True to the spirit envisioned in the campaign "Meri Maati Mera Desh" for a unified celebration of India's soil and valor, commemorating the nation's journey of freedom and progress, MSME-DFO planted saplings of fruit trees during the campaign as part of building AmritVatika.



JD & HoO hoisting the National Flag at MSME-DFO, Thrissur



As part of preparation of AmritVatika, Joint Director, MSME-DFO, Thrissur planting mango tree and Officers and staff taking PanchPran pledge

- JD & HoO administered the Swachhatha Pledge on 21.09.2023 at MSME-DFO, Thrissur to all officials as a part of Swachhatha Hi Seva Campaign. JD & HoO directed all officials to devote time towards cleaning, sorting and weeding out in spirit with the pledge. Accordingly, MSME-DFO organized various activities.



JD & HoO administering the pledge to the officials of MSME-DFO, Thrissur

- With the active participation of all officials of MSME-DFO, Thrissur, Joint Director & HoO inaugurated the Special Campaign for Disposal of Pending Matters 3.0 (SCDPM) on 01.10.2023. On 1st & 2nd October, 2023, officers and staff of MSME-DFO, Thrissur cleaned the nearby areas and public places during the campaign and also planted trees in the premises of MSME-DFO, Thrissur as a part of Special Campaign.





- As per the nomination from O/o DC (MSME) dated 19th October, 2023 Shri Prakash G S, Joint Director & HoO attended one day “Vigilance Awareness Programme” organized by National Institute for Micro, Small and Medium Enterprises (Ni.MSME), Hyderabad on 27.10.2023.
- The observance of Vigilance Awareness Week 2023 with the Theme “Say no to corruption; commit to the Nation” was organised at MSME-DFO, Thrissur by taking the integrity pledge by all the staff on 30.10.2023.



Staff of MSME-DFO, Thrissur taking the Integrity Pledge

- As a part of Rashtriya Ekta Diwas celebrations on 31.10.2023, all officials took part in the Ekta Pledge and Joint Director & HoO in his speech asked all officials to uphold unity, integrity and security of the nation.



Officials of MSME-DFO, Thrissur taking the Ekta Pledge

- On 26.01.2024, JD & HoO unfurled the National Flag of India on the occasion of the 75th Republic Day. Staff of MSME-DFO, Thrissur also attended the occasion.



75th Republic Day celebrations at MSME-DFO, Thrissur

10.6 Revenue

The following table shows the details of the Revenue earned by MSME-DFO, Thrissur during the FY 2023-24.

Details of Revenue 2023-24

Sl.No.	Particulars	Total Earning (Rs.)
1	C/F Workshop Revenue	73700
2	ESDP /MDP (Training) fees - regular courses	2,12,500
3	Others (Pl. specify) (Misc.) P.I.(Pension Id card)	100
4	Application fee under RTI Act	20
	Total:	2,86,320
5	Sale of U/S - Misc.	2,28,977
	Grand Total	5,15,297

Chapter 11

Official Language Implementation – Initiatives

11. Hindi Section's Activities

संघ सरकार की राजभाषा नीति के अनुपालन में यह कार्यालय सदैव सक्रिय है। इसके अनुपालन को सुनिश्चित करने, केलिए , व संसदीय राजभाषा समिति की तीसरी उप-समिति द्वारा किए गए निरीक्षण के दौरान दिए गए आशवासनों के क्रम में निम्नांकित उपाय किए गए हैं- अद्यतन स्थिति निम्नानुसार है

क्रमांक	दिए गए आश्वासनों का संक्षिप्त विवरण	किए गए उपाय	वर्तमान स्थिति
1	हिंदी प्रशिक्षण केलिए शोष दो एम.टी.एस. को हिंदी का आधारभूत प्रशिक्षण दिलाकर, उनसे हिंदी में सरकारी कार्य	सहायक निदेशक (राजभाषा), द्वारा संबद्ध एम.टी.एस. को हिंदी का आधारभूत प्रशिक्षण दिलाकर प्रेरणा व प्रोत्साहन के माध्यम से हिंदी में टिप्पण-लेखन करवाए गए हैं इस दिशा में सहायक निदेशक (राजभाषा), द्वारा सहायक सामग्री उपलब्ध कराई गई	एक एम.टी.एस. द्वारा हिंदी में टिप्पण-लेखन, अन्य अधिकारियों / कर्मचारियों द्वारा हिंदी कार्य में वृद्धि लक्ष्य को प्राप्त किया गया है
2	हिंदी में प्रवीणता प्राप्त अधिकारियों व कर्मचारियों द्वारा हिंदी में सरकारी कार्य करवाया जाना	कार्यालय के कुल 9 अधिकारियों व 24 कर्मचारियों में से समस्त अधिकारियों व 22 कर्मचारियों द्वारा हिंदी में सरकारी कार्य किया गया है। इस दिशा में सहायक निदेशक श्री विशेष अग्रवाल व आशुलिपिक श्रीमती शीना एस का योगदान, विशेषतः सराहनीय है	लक्ष्य-प्राप्ति- 70 प्रतिशत
3	कंप्यूटर पर हिंदी में कृत कार्य में वृद्धि व कंप्यूटर पर प्रशिक्षित लाने के संबंध में	समस्त अधिकारियों व कर्मचारियों द्वारा यथासंभव किया जा रहा है। इस ओर कंठस्थ 2.0 के प्रयोग पर हिंदी कार्यशालाएँ आयोजित हुईं, जिसमें तृशूर न.रा.का.स के सदस्य-विभाग भी शामिल हुए।	लक्ष्य-प्राप्ति- 70 प्रतिशत
4	समस्त प्रशिक्षित टाईपिस्टों द्वारा हिंदी में सरकारी कार्य कराया जाना	अधिकांश आशुलिपिकों व अपर श्रेणी लिपिकों द्वारा हिंदी में सरकारी कार्य किया जा रहा है। इस दिशा में आशुलिपिकों श्रीमती.शीना एस, श्रीमती. विजी अलेट द्वारा उल्लेखनीय प्रयास	
5	सेवा पुस्तिकाओं में हिंदी में भी प्रविष्टियाँ	संपूर्णतः की गई हैं, तथा, भविष्य में द्विभाषी प्रविष्टियाँ सुनिश्चित की गई हैं	इसे जारी रखा जाएगा
6	राजभाषा कार्यान्वयन समिति की बैठक, तिमाही आधार पर नियमित	प्रथम-27.06.23 द्वितीय-14.09.23 तृतीय-15.11.23 चतुर्थ- 27.02.24	नियमित अंतराल में बैठकों के आयोजन को सुनिश्चित किया गया है। इन बैठकों में संसदीय राजभाषा समिति द्वारा निरीक्षण के दौरान उठाए गए मदों व

			वार्षिक कार्यक्रम में निहिदों बिंदुओं के कार्यान्वयन के उपाय पर विस्तृत चर्चा की जाती है।
7	हिंदी पखवाडा 2023 के उपलक्ष्य में मुख्यालय द्वारा आयोजित प्रतियोगिता-पुरस्कार	25.09.23 को मुख्यालय द्वारा अखिल भारतीय स्तर पर आयोजित हिंदी निबंध प्रतियोगिता में इस कार्यालय की ओर से सहभागिता	परिणाम: ग क्षेत्र श्रीमती शीना एस.आशुलिपिक-द्वितीय पुरस्कार श्रीमती शरण्या के.एस.,एम.टी.एस, तृतीय पुरस्कार क क्षेत्र श्री अमितकुमार, निम्न श्रेणी लिपिक सांत्वना पुरस्कार (विजेताओं को प्रमाण-पत्रों से सम्मानित किया गया)
7	पूरा काम हिंदी में करने के लिए अनुभागों को विनिर्दिष्ट किया जाना	इस कार्यालय के क्रमशः स्थापना,लेखा,आई.पी एफ़ सी, सतर्कता ,पुस्तकालय व सांख्यिकी अनुभागों को विनिर्दिष्ट किया गया है। इस दिशा में सहायक निदेशक(सां) श्री विशेष अग्रवाल, सहायक निदेशक (रसायन) श्रीमती के. रेखा व अपर श्रेणी लिपिक श्रीमती सुजा रॉय द्वारा उल्लेखनीय प्रयास किए गए हैं। स्थापना अनुभाग के कार्यालय अधीक्षक श्रीमती सी.के जलजा व अपर श्रेणी लिपिक श्रीमती विजयलक्ष्मी द्वारा महत् प्रयास किए गए हैं	फाईलों के कवर द्विभाषी में, हिंदी पत्राचार व हिंदी टिप्पण-लेखन में वृद्धि अपेक्षित आवरण-पत्र द्विभाषी रूप में तैयार कर उपलब्ध कराए गए

वार्षिक कार्यक्रम 2023-24-लक्ष्य व उपलब्धियाँ

संघ सरकार की राजभाषा नीति के कार्यान्वयन की दृष्टि से गृह मंत्रालय, राजभाषा विभाग द्वारा वर्ष 2023-24 के लिए वार्षिक कार्यक्रम का प्रकाशन किया गया। इस कार्यालय द्वारा वार्षिक कार्यक्रम को समस्त अधिकारियों व कर्मचारियों में परिचालित किया गया। कार्यालय की हिंदी कार्यशालाओं व राजभाषा कार्यान्वयन समिति में वार्षिक कार्यक्रम में निहित लक्ष्यों की प्राप्ति पर विस्तृत चर्चा कर कमियों के निवारण के उपाय किए गए। विस्तृत ब्यौरे निम्न प्रकार है:

क्रमांक	विवरण	वार्षिक कार्यक्रम में नियत लक्ष्य	लक्ष्य-प्राप्ति	लक्ष्य-प्राप्ति के उपाय
1	धारा 3(3) का अनुपालन	शत-प्रतिशत अनुपालन	शत-प्रतिशत अनुपालन	
2	हिंदी पत्राचार	55 प्रतिशत	51 प्रतिशत	यथासंभव हिंदी पत्राचार के मानक प्रपत्र तैयार कर वितरित किए गए हैं

3	हिंदी भाषा प्रशिक्षण	कुल 9 अधिकारियों व 24 कर्मचारियों में से 9 अधिकारी व 22 कर्मचारी प्रशिक्षित		सहायक निदेशक (राजभाषा), द्वारा शेष दो एम.टी.एस. को हिंदी का आधारभूत प्रशिक्षण दिलाकर प्रेरणा व प्रोत्साहन के माध्यम से हिंदी में टिप्पण-लेखन करवाए गए हैं
4	कंप्यूटर में हिंदी का प्रशिक्षण व प्रयोग		जी हाँ	सराहनीय प्रयोग
5	हिंदी कार्यशालाएँ	प्रत्येक तिमाही के दौरान आयोजित 27.06.23 14.09.23 15.11.23 27.02.24 को आयोजित	जी हाँ	क्रमशः 15.11.23 व 27.02.24 को हिंदी संपन्न हिंदी कार्यशालाओं में तृशूर न.रा.का.स की ओर से सक्रिय सहभागिता
6	हिंदी में प्राप्त पत्रों के उत्तर	कुल 64 जिनके उत्तर हिंदी में दिए गए-7		
7	कार्यालय के समस्त फाईल कवर, रजिस्ट्रों के शीर्षक सेवा पंजी में प्रविष्टियाँ आदि	सभी द्विभाषी हैं	जी हाँ	
8	रा.का.स की बैठक	संयुक्त निदेशक व कार्यालयाध्यक्ष श्री जी एस.प्रकाश की अध्यक्षता में 37.06.23 14.09.23 15.11.23 27.02.24 को आयोजित	जी हाँ	
9	फॉर्म	कु-34 द्विभाषी 34	जी हाँ	
10	नामपट्ट व साईनबोर्ड	द्विभाषी त्रिभाषी रूप में		
11	हिंदी टिप्पण-लेखन	30 प्रतिशत	जी हाँ	
12	रबड की मोहरें	कुल 26 द्विभाषी 26	जी हाँ	
13	वेबसाईट	द्विभाषी रूप में उपलब्ध		
14	हिंदी पखवाडा 2023 का आयोजन	सफलतापूर्वक किया गया	जी हाँ	
15	प्रोत्साहन योजना	कार्यान्वयन किया जा रहा है	जी हाँ	
16	तृशूर न.रा.का.स	कार्यक्रमों में सहभागिता, समिति के तत्वावधान में 15.11.23 व 27.02.24 को हिंदी कार्यशालाएँ आयोजित हुईं	भारतीय स्टेट के तृशूर स्थित प्रशासनिक कार्यालय संयोजक हैं	

<p>हिंदी पखवाडा 2023 के उपलक्ष्य में मुख्यालय द्वारा आयोजित प्रतियोगिता-पुरस्कार</p>	<p>25.09.23 को मुख्यालय द्वारा अखिल भारतीय स्तर पर आयोजित हिंदी निबंध प्रतियोगिता में इस कार्यालय की ओर से सहभागिता</p>	<p>परिणाम: ग क्षेत्र श्रीमती शीना एस, आशुलिपिक-द्वितीय पुरस्कार श्रीमती शरण्या के.एस., एम.टी.एस, तृतीय पुरस्कार क क्षेत्र श्री अमितकुमार, निम्न श्रेणी लिपिक सांत्वना पुरस्कार (विजेताओं को प्रमाण-पत्रों से सम्मानित किया गया)</p>		
---	---	---	--	--

Chapter 12

Outcomes of Initiatives of MSME-DFO, Thrissur

This chapter embarks on a journey through the remarkable outcomes of the initiatives of MSME-DFO, Thrissur where each feedback from the beneficiary MSME stands as a testament to the transformative power of effective implementation of various Schemes of Ministry of MSME, Government of India.

12.1. K.P. Namboodiris Ayurvedics

Part - A: Details of entrepreneur			
Name of the candidate: (Shri/ Smt./Kum.)	Shri.Kolathipally Bhavadasan		
			
Address for correspondence:	NO.15, KPN'S Complex, Shornur Road, Thrissur		
Mob/Land line No.	9447142223		
Email ID.	kpna@kpnamboodiris.com www.kpnamboodiris.com		
Social status (SC/ST/OBC/PH/OC/Minority)	General		
Part - B: Details of enterprise			
Name of the Enterprise	M/s K.P. Namboodiris Ayurvedics		
Address of the Enterprise	NO.15, KPN'S Complex, Shornur Road, Thrissur		
UAM Number/ Udyam Registration No.	UDYAM-KL-13-0003711		
Category of the Enterprises (please √)	Micro	Small	Medium √
Name(s) of the Products of manufacture/services provided	Natural and Ayurvedic Products		
Date of Commencement of Production/activity	1925		
Total capital investment(Rs.)	10 Crore		
Annual Turnover (Rs)	100 Crore		
Export Details if any	Middle East		
Part - C: Details of Support provided by MSME-DFO (between 100 to 150 words)			
MSME-DFO, Thrissur has provided necessary assistance to the unit to avail different benefits from promotional agencies. On intervention of MSME-DFO, Thrissur the unit has received a sanction of Rs.0.80 lakhs as reimbursement for eight trademarks during the Financial Year 2023-24.			

Also with the assistance of MSME-DFO, Thrissur, the unit has obtained silver ZED certification. Hence, the banker of the unit has given them concessional interest rate for their loans and charged reduced processing charges. ZED certification has also resulted in a reduction of workplace accidents and injuries, contributing to improved employee well-being and higher productivity.



12.2. Millennium Rubber Technologies Pvt. Ltd

Part - A: Details of entrepreneur			
Name of the candidate: (Shri/ Smt./Kum.)	Shri.Noby Joseph		
			
Address for correspondence:	IDP, Ayyankunnu, Mundur.P.O Thrissur - 41		
Mob/Land line No.	9349760014		
Email ID.	noby1508@gmail.com		
Social status (SC/ST/OBC/PH/OC/Minority)	Minority		
Part - B: Details of enterprise			
Name of the Enterprise	M/s. Millennium Rubber Technologies Pvt. Ltd		
Address of the Enterprise	IDP, Ayyankunnu, Mundur.P.O Thrissur - 41		
UAM Number/ Udyam Registration No.	UDYAM-KL-13-0002877		
Category of the Enterprises (please √)	Micro	Small √	Medium
Name(s) of the Products of manufacture/services provided	Rubber Moulds, Technical Rubber Products		
Date of Commencement of Production/activity	2000		
Total capital investment(Rs.)	60 lakhs		

Annual Turnover (Rs)	3 Crore
Export Details if any	European Countries, UAE
Part - C: Details of Support provided by MSME-DFO (between 100 to 150 words)	
<p>The MSME unit has obtained ZED silver certification under the guidance of MSME-DFO, Thrissur. The significant benefits obtained after implementing ZED certification are as under:</p> <p>Since the MSME is already running on ISO 9001-2015 systems from earlier, the contribution of ZED was in areas related to Safety and Environmental compliances. ZED implementation has improved their workplace safety. On Environmental aspects, the unit is compliant to standards, and further they will be CO 2 emission neutral by 2028 by planting and maintaining the required number of trees. The banker (Canara Bank) has given them concessional interest rate for our loans and also charged reduced processing charges</p>	
	

12.3. Luka healthcare Private Limited

Part - A: Details of entrepreneur	
Name of the candidate: (Shri/ Smt./Kum.)	Shri.P D Varghese
Address for correspondence:	Puthen Purackal (H) Edathua P.O, Alappuzha,Kerala
Mob/Land line No.	08848851134
Email ID.	info@lukahealthcare.com https://www.lukahealthcare.com/index/

Social status (SC/ST/OBC/PH/OC/Minority)	Minority		
Part - B: Details of enterprise			
Name of the Enterprise	Luka healthcare Private Limited		
Address of the Enterprise	Puthenpurackal office no:123, Vasura Inn, Edathua P.O., Alappuzha, Kerala		
UAM Number/ Udyam Registration No.	UDYAM-KL-01-0010212		
Category of the Enterprises (please √)	Micro √	Small	Medium
Name(s) of the Products of manufacture/services provided	Integrated Medical Alert Communication System		
Date of Commencement of Production/activity	09/11/2021		
Total capital investment(Rs.)	69,58,229.76		
Annual Turnover (Rs)	Development stage		
Export Details if any	Nil		
Part - C: Details of Support provided by MSME-DFO (between 100 to 150 words)			
<p>The MSME unit mainly studies about the challenges faced by patients and nursing staff and produces many medical alarm systems. MSME-DFO, Thrissur has provided necessary assistance to the unit to avail different benefits from promotional agencies. On intervention of MSME-DFO, Thrissur the unit under the MSME Innovative Scheme Incubator Component, has submitted an application for funding for its idea through the host institute IIIT-Kottayam. The idea was reviewed and recommended to the PMAC for final approval and received a grant of Rs.8,925 lakhs (70%) as the first tranche. The funds was utilised for the development of IMACS. The INTEGRATED MEDICAL ALARM COMMUNICATION SYSTEM (iMACS) is a state-of-the-art solution designed to meet the critical needs of acute care facilities, nursing homes and long-term care facilities. The prototype developed receiving the fund by the unit is named as BEX-CALL (a wireless bed exit alarm sensor that is integrated into the nurse call). It is small and canbe attached to the patient's clothing. As soon as the patient gets out of bed, it sends a notification to the iMACS, which can be installed on the nurse's mobile device or at the nursing station. The product is tested and commercially made available in nearby Hospitals in the District.</p>			

Snapshots:



12.4. Bagmo Private Limited

Part - A: Details of entrepreneur	
Name of the candidate: (Shri/ Smt./Kum.)	Shri.Ashfaq Ashraf C 
Address for correspondence:	12/332, Anjoom, Nut Street, Vadakara, Natakkuthazha, Kozhikode- 673 104
Mob/Land line No.	99619 48748
Email ID.	ashfaq.ashraf@gmail.com https://www.bagmo.in/
Social status (SC/ST/OBC/PH/OC/Minority)	OBC
Part - B: Details of enterprise	
Name of the Enterprise	Bagmo private limited

Address of the Enterprise	12/332, Anjoom, Nut Street, Vadakara, Natakuthazha, Kozhikode- Pin 673 104		
UAM Number/ Udyam Registration No.	UDYAM-KL-08-0000987		
Category of the Enterprises (please √)	Micro √	Small	Medium
Name(s) of the Products of manufacture/services provided	1.Temperature Breach Prediction System 2.Cold chain monitoring system		
Date of Commencement of Production/activity	2/3/2017		
Total capital investment(Rs.)	6000000		
Annual Turnover (Rs)	10,74,902.19		
Export Details if any	Nil		
Part - C: Details of Support provided by MSME-DFO (between 100 to 150 words)			
<p>Bagmo Pvt Ltd is a healthcare startup based out of Kochi, Kerala. It focuses on solving the healthcare needs of the country using engineering innovations and operation management techniques. Bagmo is a spin-out company of BIRAC's Social Innovation Immersion program on maternal and child health. It has been awarded the grant in aid support for its efforts in healthcare technology development. Their product LoggFi is a connected temperature logger, which we can use for cold chain logistics. It will track the temperature of the products throughout to ensure an unbroken cold chain. LoggFi is used for temperature-sensitive bio-chemicals like vaccines and other pharma products, perishable food items. MSME-DFO, Thrissur has provided necessary assistance to the unit to avail different benefits from promotional agencies. On intervention of MSME-DFO, Thrissur the idea for prototype development of LoggFi were submitted through Maker Village (Host Institute) seeking fund under MSME Idea Hackathon 2.0. The idea was reviewed and recommended to the PMAC for final approval and received a grant of Rs.8,925 lakhs (70%) as the first tranche. The funds was utilised for the development of LoggFi. The product is now produced and available in market.</p>			
			

12.5. K.P. Namboodiris Ayurvedics

Part - A: Details of entrepreneur			
Name of the candidate: (Shri/ Smt./Kum.)	Shri. E T Neelakandan Mooss		
			
Address for correspondence:	14/473/1, Vaidyaratnam Oushadhasala P Ltd, Thaikkattussery Road, Ollur, Thaikkattussery P O, Thrissur		
Mob/Land line No.	7994435901		
Email ID.	vosmfa@vaidyaratnammooss.com		
Social status (SC/ST/OBC/PH/OC/Minority)	General		
Part - B: Details of enterprise			
Name of the Enterprise	M/s K.P. Namboodiris Ayurvedics		
Address of the Enterprise	NO.15, KPN'S Complex, Shornur Road, Thrissur		
UAM Number/ Udyam Registration No.	UDYAM-KL-13-0000663		
Category of the Enterprises (please √)	Micro	Small	Medium √
Name(s) of the Products of manufacture/services provided	Natural and Ayurvedic Products		
Date of Commencement of Production/activity	2011		
Total capital investment(Rs.)	10 Crore		
Annual Turnover (Rs)	100 Crore		
Export Details if any	Middle East		
Part - C: Details of Support provided by MSME-DFO (between 100 to 150 words)			
MSME-DFO, Thrissur has provided necessary assistance to the unit to avail different benefits from promotional agencies. On intervention of MSME-DFO, Thrissur the unit has received a reimbursement of Rs.1.37 lakhs for fifteen trademarks during the Financial Year 2023-24.			



12.6. Best India Food Processing Private Limited

Part - A: Details of entrepreneur			
Name of the candidate: (Shri/ Smt./Kum.)	Shri. Aboobacker.V.K		
Address for correspondence:	17/485F, Best India Food Processing Private Limited, Kadampuzha Road Thaniyapankunu, Edayur, Kuttippuram, Valanchery		
Mob/Land line No.	8156955083		
Email ID.	enquiry@babyvitaindia.com https://www.bestindiafood.com/		
Social status (SC/ST/OBC/PH/OC/Minority)	OBC		
Part - B: Details of enterprise			
Name of the Enterprise	M/s Best India Food Processing Private Limited		
Address of the Enterprise	17/485F, Best India Food Processing Private Limited, Kadampuzha Road Thaniyapankunu, Edayur, Kuttippuram, Valanchery		
UAM Number/ Udyam Registration No.	UDYAM-KL-09-0000709		
Category of the Enterprises (please √)	Micro	Small √	Medium
Name(s) of the Products of manufacture/services provided	Food products		
Date of Commencement of Production/activity	1991		
Total capital investment(Rs.)	25 lakhs		
Annual Turnover (Rs)	50 Crore		
Export Details if any			
Part - C: Details of Support provided by MSME-DFO			

(between 100 to 150 words)

MSME-DFO, Thrissur has provided necessary assistance to the unit to avail different benefits from promotional agencies. On intervention of MSME-DFO, Thrissur the unit has received a sanction of Rs.1.20 lakhs as reimbursement for thirteen trademarks during the Financial Year 2023-24.

**12.7. Creativiti Council**

Part - A: Details of entrepreneur			
Name of the candidate: (Shri/ Smt./Kum.)	Shri. James T.J.		
			
Address for correspondence:	A1 Bhavani Residency Poothole PO Thrissur , Pin 680004		
Mob/Land line No.	9496373946		
Email ID.	creativiticouncil@gmail.com https://www.creativiticouncil.org/		
Social status (SC/ST/OBC/PH/OC/Minority)	General		
Part - B: Details of enterprise			
Name of the Enterprise	Creativiti Council		
Address of the Enterprise	Kariattukara , Elthuruthu PO Thrissur , Kerala : Pin 680004		
UAM Number/ Udyam Registration No.	UDYAM-KL-13-0031453		
Category of the Enterprises	Micro	Small	Medium

(please ✓)	✓		
Name(s) of the Products of manufacture/services provided	Self-Operated Backrest (Manual &Electric with communication system)		
Date of Commencement of Production/activity	August 2nd, 2017		
Total capital investment(Rs.)	15 Lakhs		
Annual Turnover (Rs)	16 Lakhs in 2022-23		
Export Details if any	Nil		

Part - C: Details of Support provided by MSME-DFO (between 100 to 150 words)

Creativiti Council is a MSME formed by group of innovators and they are addressing several unique and neglected needs in the society. It has been noted that; the majority of the technological needs of palliative care patients are yet to be identified and catered and thus the idea of self-operated bed recliner for bed-ridden patients came. For funding of the development of prototype, the MSME unit approached MSME-DFO and as per the advice received from MSME-DFO, Thrissur they submitted the application seeking fund under MSME Innovative Scheme through Host Institute Maker Village. The idea of backrest with additional features was reviewed and recommended to the PMAC for final approval and received a grant of Rs.7.925 lakhs (70%) as the first tranche. The funds was utilised for the development of the product. The product is now produced and available in market.





12.8. Hykon India Limited

Part - A: Details of entrepreneur			
Name of the candidate: (Shri/ Smt./Kum.)	Shri.Christo George		
			
Address for correspondence:	Hykon India Limited, Ikkanda warrier Road, Thrissur, Kerala - 680 001		
Mob/Land line No.	91-487-2444183		
Email ID.	christo@hykonindia.com http://www.hykonindia.com/		
Social status (SC/ST/OBC/PH/OC/Minority)	Minority		
Part - B: Details of enterprise			
Name of the Enterprise	Hykon India Limited		
Address of the Enterprise	Hykon India Limited, Ikkandawarrier Road, Thrissur, Kerala - 680 001		
UAM Number/ Udyam Registration No.	UDYAM-KL-13-0000840		
Category of the Enterprises (please √)	Micro	Small √	Medium
Name(s) of the Products of manufacture/services provided	UPS, Inverter, Electric Vehicle, Stabilizer, Solar Water Heater, Lithium Battery etc.		
Date of Commencement of Production/activity	1991		
Total capital investment(Rs.)	5 crore		

Annual Turnover (Rs)	100 crore
Export Details if any	Argentina, Italy, UK, US, Italy, Brazil, China, Luxumberg

**Part - C: Details of Support provided by MSME-DFO
(between 100 to 150 words)**

The MSME unit has obtained ZED silver certification under the guidance of MSME-DFO, Thrissur. The significant benefits obtained after implementing ZED certification are as under:

Workplace Safety: As an ISO and ISO TS certified company, they have already well-established systems in place for workplace safety and employee welfare. However, ZED certification has further enhanced and ensured compliance with safety standards and regulations. This has resulted in a reduction of workplace accidents and injuries, contributing to improved employee well-being and higher productivity. Moreover, it has enabled them to mitigate costs associated with accidents and medical expenses. They received financial assistance of 75% for product testing. They have included the ZED points in their audit checklist to ensure that employees have a well-organized work environment.

Energy, Environmental, Risk, and Waste Management: As part of their resource conservation initiatives, they have implemented a solar system in the plant and enhance energy efficiency and environmental sustainability efforts.

Financial Support: The unit has received a 0.25% interest reduction on the term loan facilities availed from the financial institutions. Additionally, they have obtained a 25% reduction in processing fees for these term loans after obtaining ZED certification.



12.9. RIM Projects

Part - A: Details of entrepreneur

Name of the candidate:
(Shri/ Smt./Kum.)





Address for correspondence:	12/372(2),Karunalayamroad, near YWCA, Aluva, Kerala-683101		
Mob/Land line No.	0484-2624562		
Email ID.	rahuliype@rimprojects.com		
Social status (SC/ST/OBC/PH/OC/Minority)	General		
Part - B: Details of enterprise			
Name of the Enterprise	RIM PROJECTS		
Address of the Enterprise	12/372(2),Karunalayamroad, near YWCA, Aluva, Kerala-683101		
UAM Number/ Udyam Registration No.	UDYAM-KL-02-0011965		
Category of the Enterprises (please √)	Micro	Small √	Medium
Name(s) of the Products of manufacture/services provided	Electrical distribution box AC Combiner box DC Combiner box Customized and Compartmentalized DBs. 		
Date of Commencement of Production/activity	NA		
Total capital investment(Rs.)	NA		
Annual Turnover (Rs)	Rs. 3 crores		
Export Details if any			
Part - C: Details of Support provided by MSME-DFO (between 100 to 150 words)			
<p>RIM PROJECTS is into designing products and systems that optimize resource utilization. Their commitment to renewable energy stems from the desire to foster a sustainable relationship with nature, minimizing waste at every turn. They have extensively tested various products available in the market before venturing into business. Their meticulous product analysis and market study ensure that only high-quality products, capable of seamless integration within complete systems, are selected for customers.</p> <p>The enterprise participated in KREEPA Green Power Expo 2023 under 5 I(A) of PMS scheme and got financial assistance from MSME-DFO, Thrissur for the stall space rent charges and contingency expenditures of the exhibition. They were able to showcase their products like AC and DC distribution boxes, both Customized and Compartmentalized DBs. They were able to provide valuable insights on ensuring safety during both the installation and operation phases. Following exhibitions, they experienced a notable increase in inquiries about Electrical distribution box which was made possible with the financial support from Ministry of MSME.</p>			





12.10. Kraft Work Solar Pvt Ltd

Part - A: Details of entrepreneur			
Name of the candidate: (Shri/ Smt./Kum.)	K. NEELAKANTA IYER		
			
Address for correspondence:	29/2862,ADITHYA,NR. GANDHISQUARE,COCHIN-682038		
Phone No	7994615230		
Email ID.	info@kraftworksolar.com		
Social status (SC/ST/OBC/PH/OC/Minority)	General		
Part - B: Details of enterprise			
Name of the Enterprise	KRAFT WORK SOLAR PVT LTD		
Address of the Enterprise	29/2862, ADITHYA NR. GANDHISQUARE,COCHIN-682038		
UAM Number/ Udyam Registration No.	UDYAM-KL-02-0012516		
Category of the Enterprises (please √)	Micro √	Small	Medium
Name(s) of the Products of manufacture/services provided	Solar Drier, Solar water Heater		

	
Date of Commencement of Production/activity	NA
Total capital investment(Rs.)	NA
Annual Turnover (Rs)	4 Cr.
Export Details if any	
Part - C: Details of Support provided by MSME-DFO (between 100 to 150 words)	
<p>Kraftwork Solar Pvt Ltd is an ISO Certified company providing wide range of Products and Services in the field of Renewable Energy Industry with more than 10000 Installations across India and Abroad.</p>	
<p>Assistance given by MSME-DFO, Thrissur was the reimbursement of the expenses involved in participating in KREEPA Green Power Expo under PMS Scheme. They could display their new solar Drier in the exhibition by Kreepa, and as a result, their turnover has been increased by 30%. They experienced a good response from the customers and government agencies and received a good number of orders.</p>	
	

12.11. Tharayil Power & Energy Solutions Pvt Ltd

Part - A: Details of entrepreneur			
Name of the candidate: (Shri/ Smt./Kum.)	Munia Thulaseedas 		
Address for correspondence:	Tharayil House, Kalath Ward, Avalukkunnu PO, Alappuzha-688006		
Phone No	90743536		
Email ID.	thulsi@tharayilpower.com		
Social status (SC/ST/OBC/PH/OC/Minority)	OBC		
Part - B: Details Of Enterprise			
Name of the Enterprise	Tharayil Power & Energy Solutions Pvt Ltd		
Address of the Enterprise	Tharayilhouse, Kalath Ward, Avalukkunnu Po, Alappuzha-688006		
UAM Number/ Udyam Registration No.	UDYAM-KL-01-0004416		
Category of the Enterprises (please ✓)	Micro ✓	Small	Medium
Name(s) of the Products of manufacture/services provided	Solar Products 		
Date of Commencement of Production/activity	NA		
Total capital investment(Rs.)	NA		
Annual Turnover (Rs)	5 Cr.		
Export Details if any			
Part - C: Details of Support provided by MSME-DFO (between 100 to 150 words)			

They are focusing on solar power plant installations for domestic and commercial sectors and currently executing SMNRE Soura subsidy program.

They have received Financial Assistance from MSME DFO, Thrissur under PMS Scheme of Ministry of MSME for participating in the Green Power Expo of KREEPA. They were able to meet more than 500 clients during the expo at Bolgaty Palace, Kochi and could generate business for Rs. 43 lakh from the Expo.



12.12. Wattsun Energy India Pvt Ltd

Part - A: Details of entrepreneur

Name of the candidate:
(Shri/ Smt./Kum.)

Terance Alex



Address for correspondence:	FF Aiswarya Towers International Airport Road Chackai- Thiruvananthapuram Kerala-India- 695024		
Mob/Land line No.	9388106363		
Email ID.	info@wattsun.in		
Social status (SC/ST/OBC/PH/OC/Minority)	General		
Part - B: Details of enterprise			
Name of the Enterprise	Wattsun Energy India PVT LTD		
Address of the Enterprise	FF Aiswarya Towers International Airport Road Chackai- Thiruvananthapuram Kerala-India- 695024		
UAM Number/ Udyam Registration No.	UDYAM-KL-12-0004686		
Category of the Enterprises (please √)	Micro	Small √	Medium
Name(s) of the Products of manufacture/services provided	Solar EPC-Solar Roof Top Power plants, Solar powered Cold Storage, EV charging Stations		
			
Date of Commencement of Production/activity	NA		
Total capital investment(Rs.)	NA		
Annual Turnover (Rs)			
Export Details if any			
Part - C: Details of Support provided by MSME-DFO (between 100 to 150 words)			
<p>Wattsun Energy India Pvt Ltd is an ISO 50001-2011 Energy Management Systems Certified Company. As an EPC (Engineering Procurement and Constructing), Wattsun provides consultancy services starting from concept to commissioning of solar power plants and also service and maintenance.. It also strongly support Make in India Concept and also local empowerment hence started “Wattsun Academy & Research Center” it’s one wing aimed to train and develop skilled manpower for perfection in execution of solar projects. Wattsun Academy has been accredited by Skill Council for Green Jobs under National Skill development Corporation, New Delhi.</p> <p>They were able to capitalize more business after participating in the KREEPA Green</p>			

Power Expo under PMS scheme and got financial assistance from MSME-DFO, Thrissur. This aid helped them in three ways. First as a branding they could take a bronze stall and make their firm as one of leading player in Kerala, Secondly they could build confidence in manufactures and suppliers of RE products & finally they could generate good revenue and new market access.





MINISTRY OF MICRO, SMALL & MEDIUM ENTERPRISES
GOVERNMENT OF INDIA

VISIT CHAMPIONS AT

www.champions.gov.in



**Our small hands to
make you LARGE**